

 Applies To: **1996–98 Civic HX With CVT – All**
**June 25, 2002**

## Shudder, Judder, Surging, Shock, Noise, or Idle Fluctuation

 (Replaces 99-068, *Surge at Highway Speeds*, dated April 11, 2000, and 99-069, *Idle Fluctuates When Engine Is Cold*, dated December 19, 2000)

### SYMPTOM

The vehicle may have one or more of these symptoms:

- Idle fluctuates between 500 and 1,500 RPM (The fluctuation is more pronounced before the engine reaches normal operating temperature.)
- Shudder or judder when accelerating from a stop or just before stopping
- Surging at highway speeds between 2,000 and 3,000 RPM
- Excessive shock when the engine is cold and you start to accelerate
- A “coo” sound, lasting about 5 to 10 seconds, after coming to a stop

### PROBABLE CAUSE

The problem may have one or more of these causes:

- TCM control unit programming is too sensitive.
- The start clutch assembly is worn.
- The start clutch control valve is contaminated.

### CORRECTIVE ACTION

Replace the start clutch assembly, the start clutch control valve, and the TCM.

### PARTS INFORMATION

Start Clutch Kit: P/N 06220-P2M-305, H/C 7073448

 Honda ATF-Z1 (seven quarts required):  
 P/N 08200-9001, H/C 6512628

### REQUIRED SPECIAL TOOLS

Start Clutch Remover: T/N 07TAE-P4VA120

Start Clutch Installer: T/N 07TAE-P4VA130

### WARRANTY CLAIM INFORMATION

**In warranty:** The normal warranty applies.

Operation Number: 219167

Flat Rate Time: 6.0 hours

 Failed Part: P/N 22020-P4V-325  
 H/C 5192349

Defect Code: 034

Contention Code: C99

Template ID: 02-003A

Skill Level: Repair Technician

**Out of warranty:** Any repair performed after warranty expiration may be eligible for goodwill consideration by the District Parts and Service Manager or your Zone Office. You must request consideration, and get a decision, before starting work.

### REPAIR PROCEDURE

**NOTE:** Make sure the work surface and the CVT are completely clean. Use lint-free towels, and use a dedicated, clean solvent tank for cleaning the CVT parts. If you do not keep everything very clean, the repair may not be successful.

1. Soak the new start clutch assembly in Honda ATF-Z1 for at least 30 minutes.

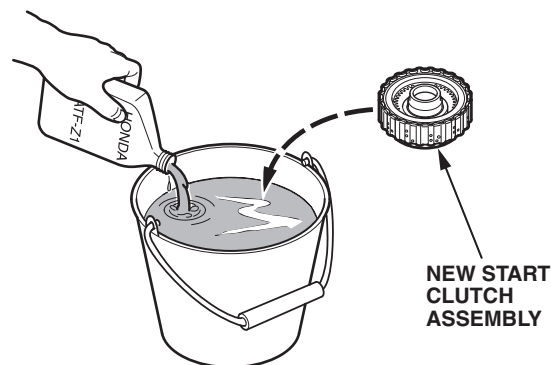

2. Remove the transmission from the vehicle. See page 14-304 of the 1996–00 Civic Service Manual.
3. Cover with clean shop towels all of the openings in the transmission and anything else that might get damaged by water and cleaning chemicals (axle openings, breather, and electrical connectors). Clean all the dirt and grease off of the transmission before you start disassembly.

4. Place the transmission on a work bench with the flywheel housing facing upward.
5. Remove the ATF passage line holder from the flywheel housing.

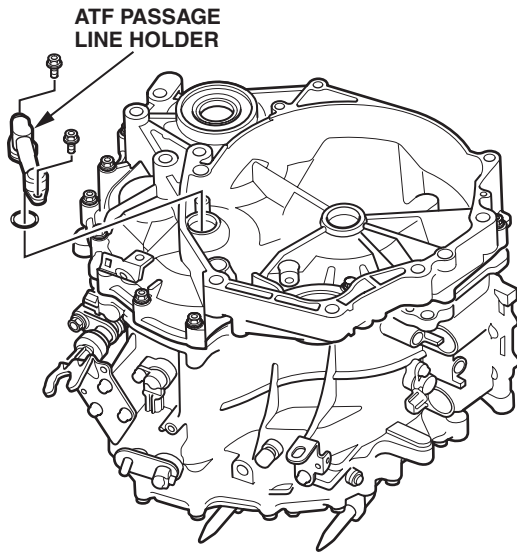

6. Remove the flywheel housing (20 bolts).

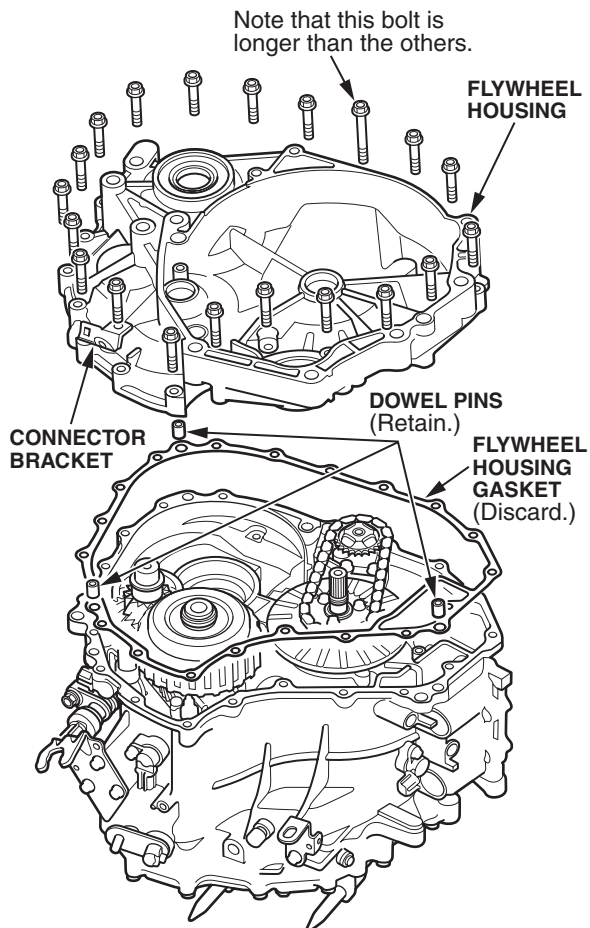

7. Remove the differential assembly from the transmission case.

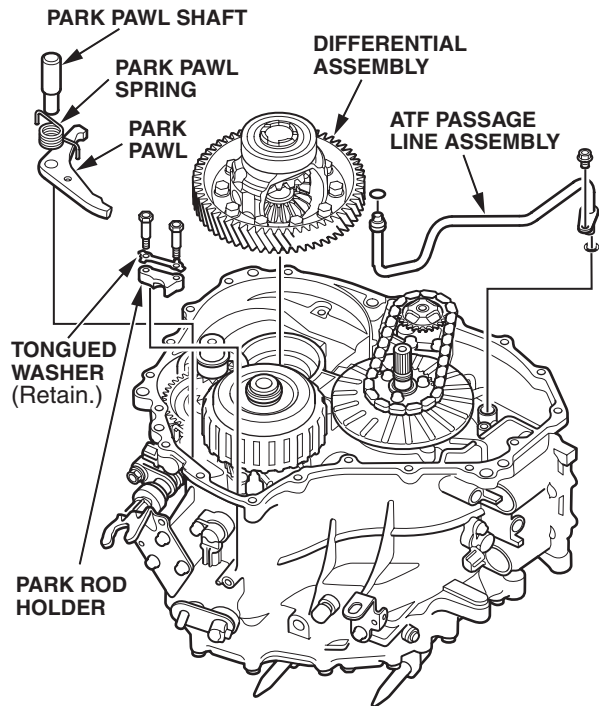

8. Remove the ATF passage line assembly.
9. Remove the park pawl shaft, then remove the park pawl and spring.
10. Remove the park rod holder.
11. Remove the snap ring, the cotter retainer, and the cotters from the start clutch assembly.

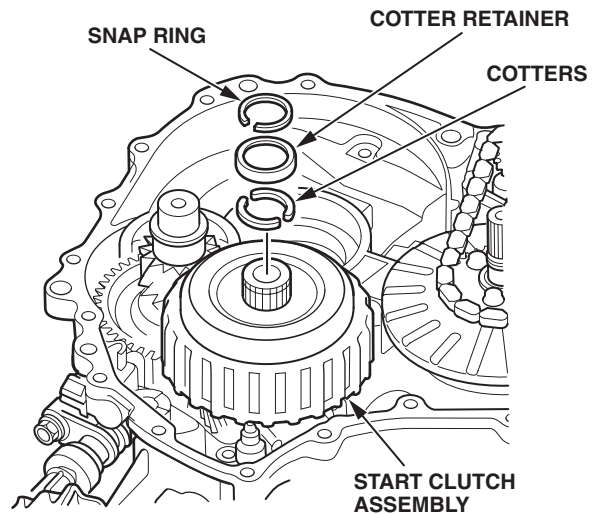

12. Remove the start clutch assembly with the special tool.

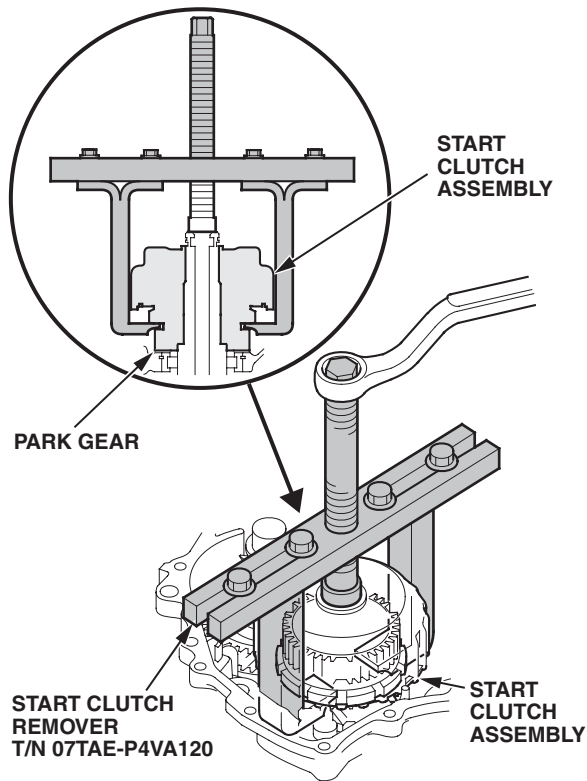

13. Remove the start clutch assembly from the hub. Clean and lubricate the hub with ATF-Z1, and then install the new start clutch assembly from the kit.

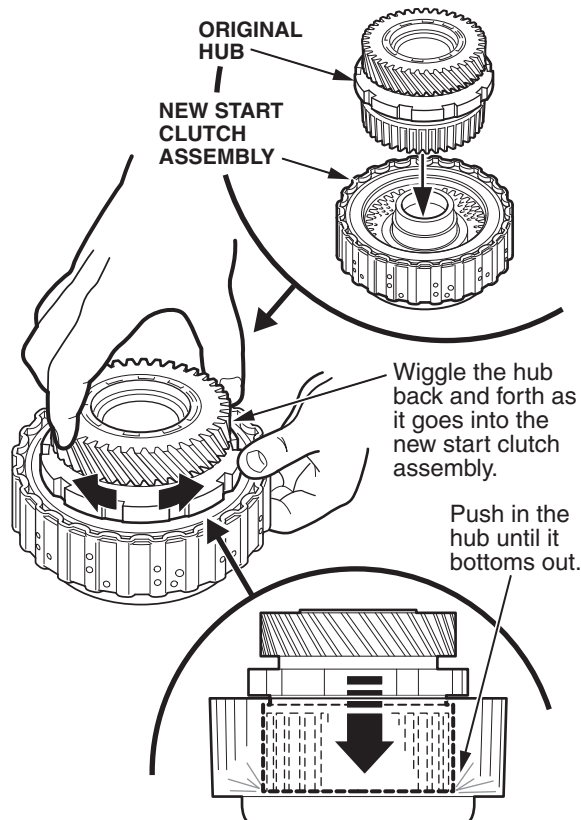

14. Lubricate the O-rings with ATF-Z1. Replace the three O-rings on the driven pulley shaft with new ones from the kit.

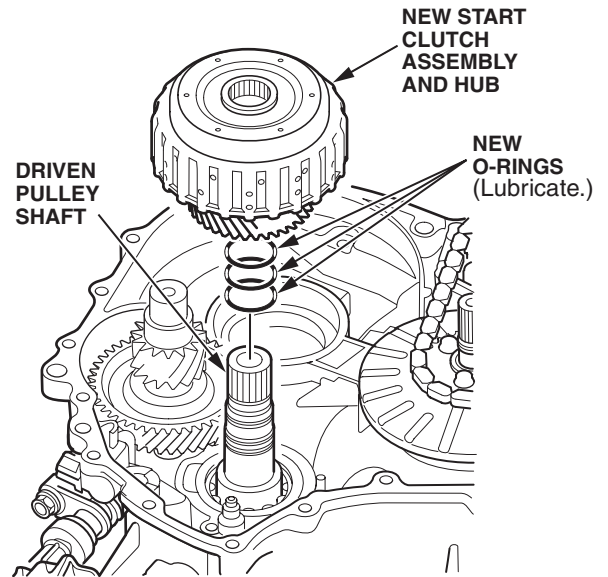

15. Place the new start clutch assembly on the driven pulley shaft.

16. Seat the start clutch assembly by aligning the tip of the special tool with the shaft hole and then pushing down the handle.

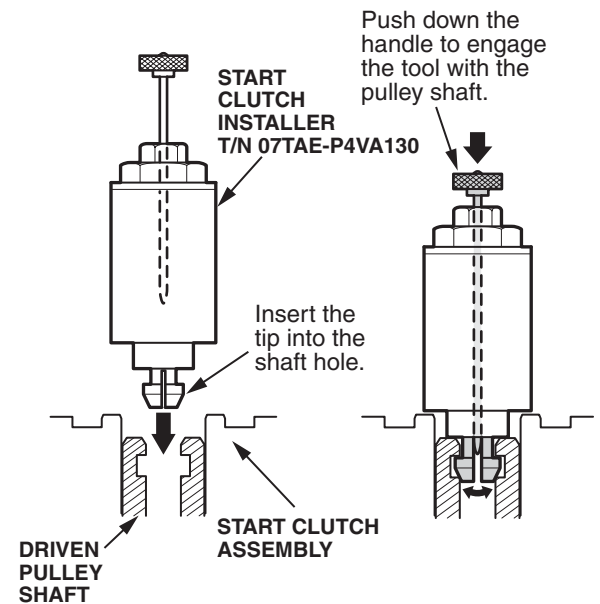

17. While holding the handle down, push the hexagonal part of the tool, on the bottom, until it contacts the seating surface of the start clutch assembly.

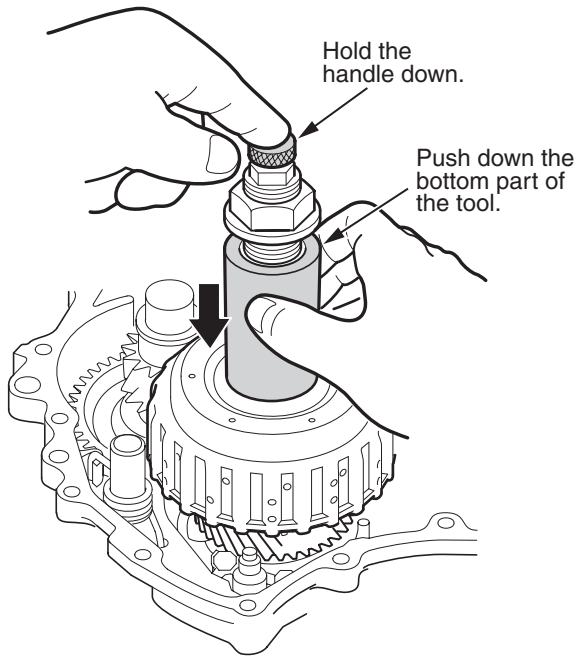

18. Use a 19 mm wrench to hold the upper hexagonal section of the special tool. Use an adjustable wrench to tighten the lower hexagonal section until the gear seats.

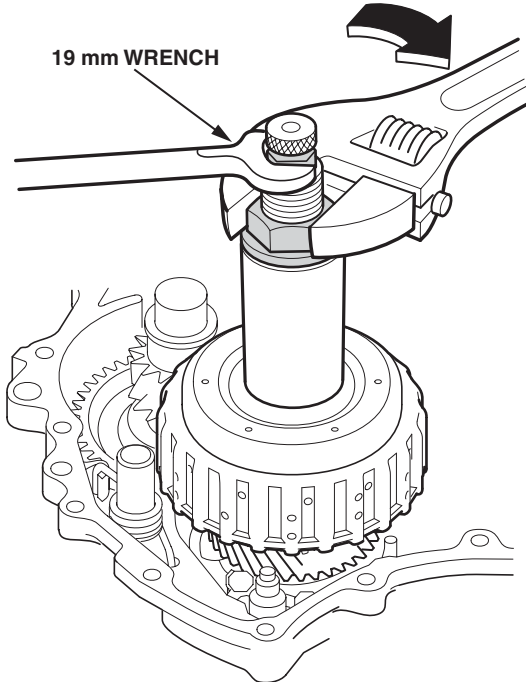

19. Remove the special tool.

20. Assemble the cotters into the channel in the driven pulley shaft, then measure the clearance between the cotter and the start clutch guide. Measure the clearance at three locations, and then average them. Is the average clearance 0 to 0.13 mm?

- Yes - Go to step 22.
- No - Go to step 21.

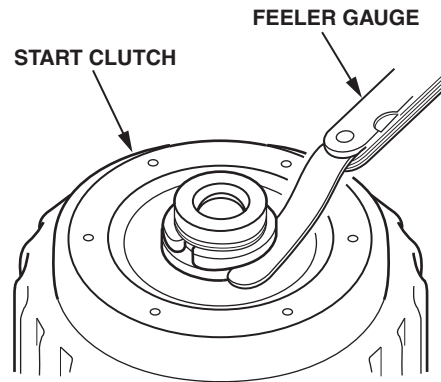

21. Select the appropriate cotter from the table, and adjust the clearance.

Cotter	Part Number	H/C	Thickness (mm)
A	90429-P4V-000	4905576	2.9
B	90430-P4V-000	4905584	3.0
C	90431-P4V-000	4905592	3.1
D	90432-P4V-000	4905600	3.2

22. Install the cotter retainer and the snap ring.

23. Assemble the park pawl, the spring, the shaft, and the park rod holder.

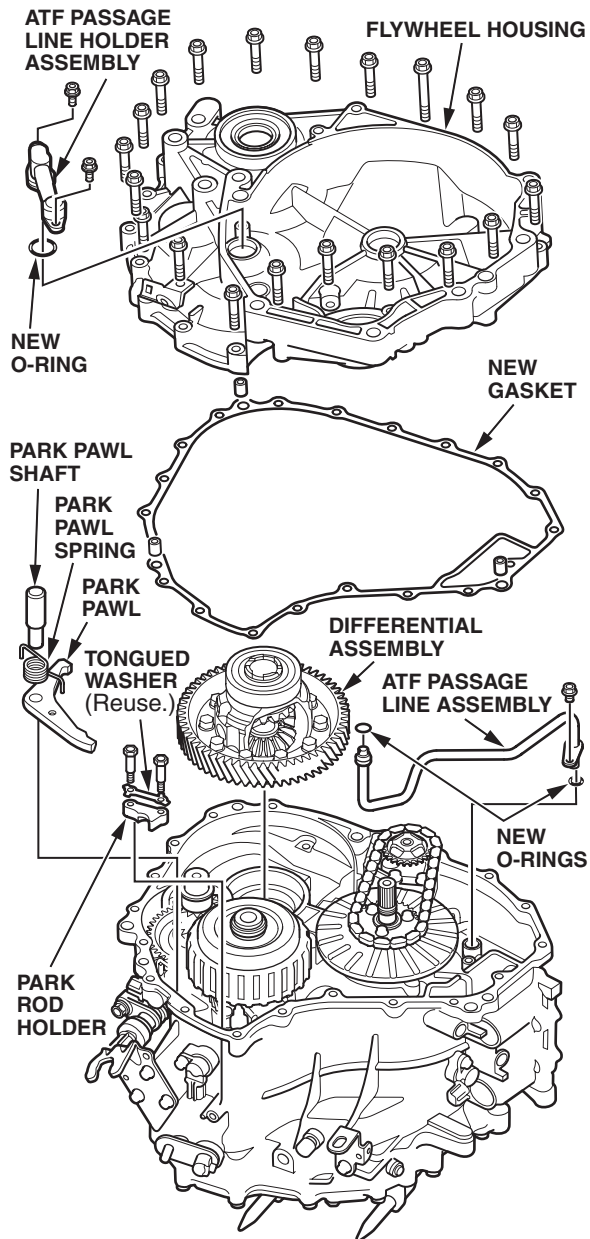

24. Install the ATF passage line assembly with two new O-rings.

25. Install the differential assembly.

26. Install the flywheel housing with a new gasket. Torque the bolts to 29 N·m (22 lb-ft). Install a new O-ring onto the ATF passage line holder assembly, and install the assembly into the flywheel housing.

27. Remove the ATF pan (14 bolts). Remove the two dowel pins so they don't fall out and get lost.

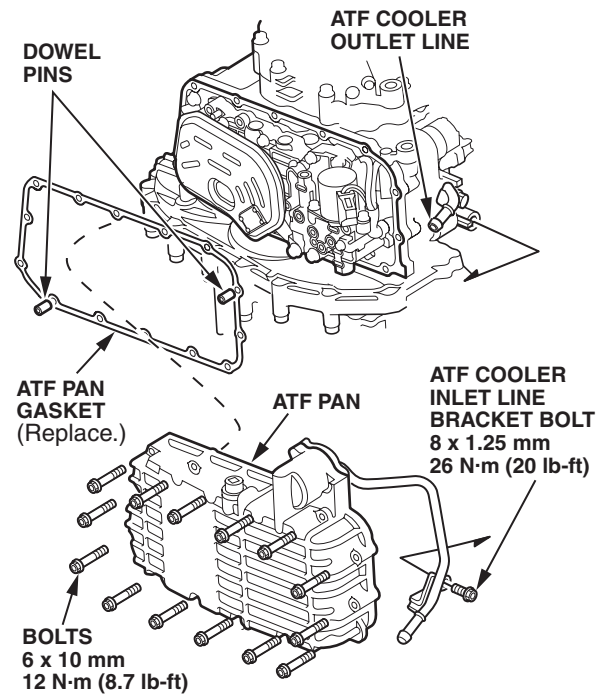

28. Remove the ATF strainer (two bolts) and the solenoid harness connector (one bolt).

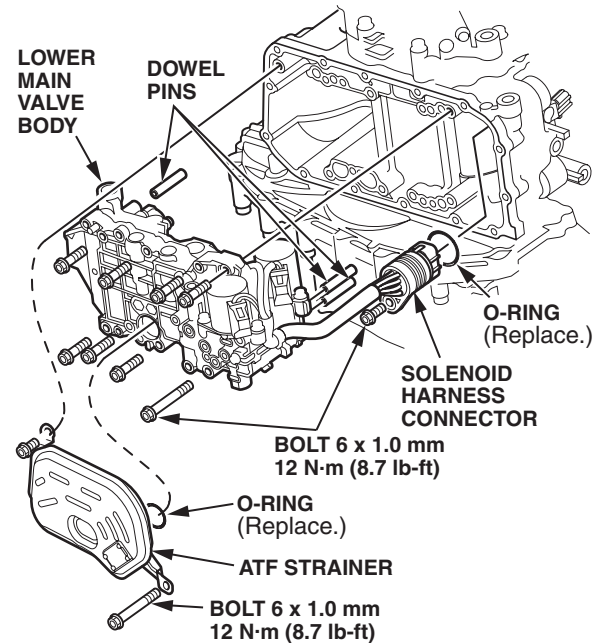

29. Remove the lower main valve body (eight bolts). Remove the three long dowel pins that locate the lower main valve body assembly. Note the locations of the dowel pins.

30. Place the lower main valve body on the bag the replacement solenoid came in. Disconnect the 2P connector from the start clutch control solenoid. Remove the start clutch control solenoid (four bolts). Note the locations of the dowel pins, the filter, and the separator plate, then remove them. Discard the start clutch control solenoid.

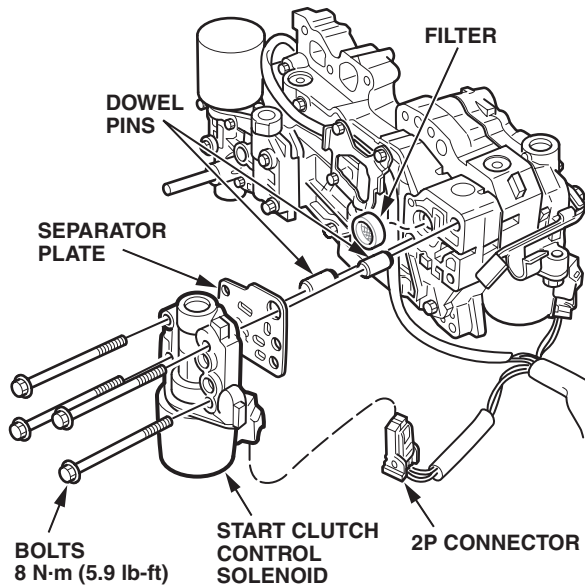

31. Install the two dowel pins and the filter into the valve body. Install the separator plate onto the valve body. Install the new start clutch control solenoid, making sure you do not pinch the harness. Connect the 2P connector (the connector with the PNK/BLK and YEL wires) to the start clutch control solenoid. Torque all four bolts to 8 N-m (5.9 lb-ft).

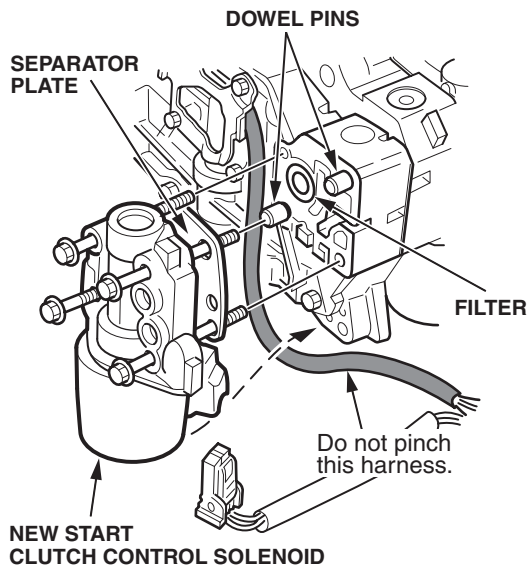

32. Install new O-rings from the repair kit onto the solenoid harness connector and the ATF strainer.

33. Install the three long dowel pins into the lower main valve body, then install the lower main valve body into the transmission case (eight bolts). Torque the bolts to 12 N-m (8.7 lb-ft).
34. Install the ATF strainer (two bolts) and the solenoid harness connector (one bolt). Torque the bolts to 12 N-m (8.7 lb-ft).
35. Install the ATF pan with a new gasket from the repair kit. Torque the bolts to 12 N-m (8.7 lb-ft).
36. Reinstall the transmission into the vehicle. Fill it with 6.8 quarts of Honda ATF-Z1 fluid.
37. Disconnect the two TCM connectors, loosen the lower and right side mounting bolts, remove the left side mounting bolt, and remove the TCM.

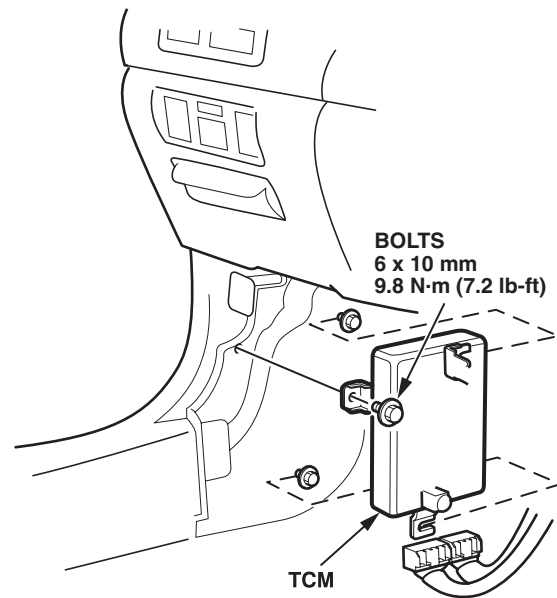

38. Install the new TCM in the reverse order of removal.
39. Perform the Start Clutch Calibration Procedure for '97-00 Models on page 14-293 of the 1996-00 Civic Service Manual. Follow the 1997-00 Model procedure for all years; the new TCM has the auto learning mode.
40. Check the fluid level, and refill as needed.