

TO: ALL TOYOTA DEALER PRINCIPALS,
SERVICE MANAGERS, PARTS MANAGERS

SUBJECT: SPECIAL SERVICE CAMPAIGN – 60I
(CERTAIN 2001 THROUGH 2003 MODEL YEAR 4-CYLINDER HIGHLANDER AND CERTAIN
2001 THROUGH 2002 MODEL YEAR RAV4 ECM REPROGRAMMING)

Toyota will initiate a Special Service Campaign to reprogram the Engine Control Module (ECM) on certain 2001 through 2003 Model Year 4-cylinder Highlander vehicles, and certain 2001 through 2002 Model Year RAV4 vehicles. There are approximately 220,000 vehicles involved nationwide.

In recent months, Toyota has received reports that some customers may experience a specific Malfunction Indicator Light (check engine light) “ON” condition (P0420 or P0430). Toyota has investigated these concerns and discovered an issue with the program logic in the Engine Control Module (ECM). New program logic has been developed to correct this condition.

The following vital information is provided to inform you and your staff of the owner notification phase of the campaign and your degree of involvement.

1. Owner Notification Letter Mailing Date

The owner notification will commence in mid-December, 2006. The owner letters will be mailed over a one month period.

As always, please **verify vehicle eligibility by confirming through Dealer Daily/TIS prior to performing the reprogramming**. Dealers should perform the reprogramming as outlined in the repair manual and attached Technical Instructions.

2. Dealer/Owner Lists

Affected vehicle VIN lists (VIN only due to changes in Privacy Laws) for the SSC 60I campaign have been distributed to each dealership’s Service and Parts Managers. These lists are based upon the dealership’s Primary Marketing Area (PMA) or selling dealership where applicable. Based upon our records, a dealership which does not have an affected vehicle in their PMA will receive a report indicating so.

3. Number and Identification of Involved Vehicles

There are approximately 220,000 Highlander and RAV4 (2001 through 2003 Model Year 4-cylinder Highlander, and 2001 through 2002 Model Year RAV4) vehicles involved in the U.S.

MODEL	MY	VIN Range	
		VDS	Range
Highlander	2001	GD21A	0001024 - 0020971
		HD21A	0001016 - 0010592
	2002	GD21A	0020972 - 0046738
		HD21A	0010594 - 0018656
	2003	GD21A	0046739 - 0073654
		HD21A	0018659 - 0025429
RAV4	2001	GH20V	0001008 - 0041683
		HH20V	0018795 - 0129192 6000000 - 6013768
	2002	GH20V	0040732 - 0078543 6000000 - 6009535
		HH20V	0127491 - 0181148 6012461 - 6066600

Please note that not all vehicles in the VIN range are affected by this SSC. If a dealer is contacted by an owner of an involved vehicle, who has not yet received a notification, please instruct them to **verify eligibility by confirming through Dealer Daily/TIS prior to performing repairs**. Dealers should perform the inspection and repair as outlined in the attached Technical Instructions

4. Parts Ordering

No parts will be necessary for the completion of SSC 60I.

5. Warranty Processor Instructions

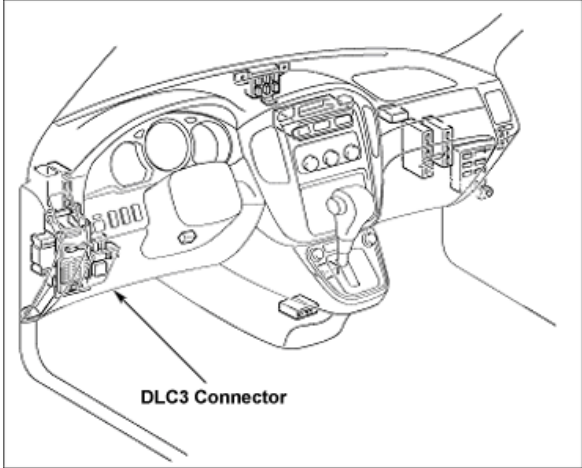
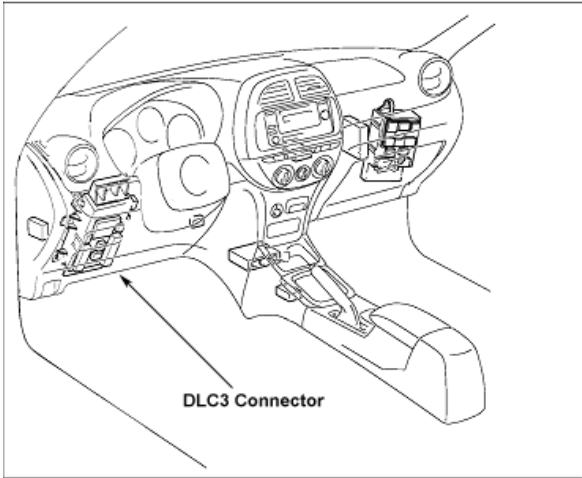
<div style="border: 2px solid red; padding: 5px; margin-bottom: 10px; text-align: center;"> <p><i>Download the Calibration Software from TIS to the Toyota Diagnostic Tester or Toyota Techstream.</i></p> </div> <div style="text-align: center;">↓</div> <div style="border: 2px solid red; padding: 5px; margin-bottom: 10px; text-align: center;"> <p>Reprogram the ECM</p> </div> <div style="text-align: center;">↓</div> <div style="border: 2px solid red; padding: 5px; text-align: center;"> <p>Install the Recalibration Update Label</p> </div>	<p>Certain 2001 Through 2003 Model Year Highlander Certain 2001 Through 2002 Model Year RAV4 Engine Control Module Reprogramming</p> <div style="text-align: center;">  <p>Highlander</p> </div> <div style="text-align: center;">  <p>RAV4</p> </div>
---	--

Submit Special Service Campaign claims following the procedures described in the Toyota Warranty Policy and Procedures Manual.

The operation codes to be used for this campaign are:

SSC #	Op. Code	Description	Flat Rate Hour
60I	6621J1	<ul style="list-style-type: none"> • Check the current Engine Control Module Calibration. 	0.2 Hr/Veh
	6621J2	<ul style="list-style-type: none"> • Check the current Engine Control Module Calibration. • Reprogram the Engine Control Module. 	0.6 Hr/Veh

NOTE:

- The above flat rate time(s) include 0.1 hour in each campaign for administrative cost per unit for the dealership.

6. Reimbursement for Catalytic Converter replacement prior to the launch of this SSC

Customers may request reimbursement, if they have previously paid for the program update or, in the rare instance, the replacement of the Catalytic Converter for this specific condition prior to receiving the owner letter. Customers requesting reimbursement are requested to mail a copy of their repair order, proof-of-payment, and proof-of-ownership to the following address for reimbursement consideration:

Toyota Motor Sales, U.S.A., Inc.
Customer Experience, WC10
19001 South Western Avenue
Torrance, CA 90509

They must include their name, address, and telephone number(s) in the request. It will take approximately 4 to 6 weeks to review their request.

7. Vehicles Registered in the State of California

The State of California requires the completion of Special Service Campaigns on emission-related components prior to vehicle registration renewal. The state also mandates the submission of non-completed California VINs to the state Department of Motor Vehicles (DMV) by each auto manufacturer. Dealers in California will be requested to complete a Vehicle Emissions Recall Proof of Correction Form after the campaign has been completed to assure customers are able to provide proof of completion if requested by the DMV.

8. Vehicles Emission Recall Proof of Correction Form (California only)

As this Special Service Campaign includes emission related parts, California dealers are requested to fill out the Vehicle Emissions Recall – Proof of Correction form after repairs have been completed. The vehicle owner may require this form for vehicle registration renewal. One book of the form has been included in the Service Managers package for dealers in California. ***It is important to note that the forms are an official state document and blank forms must be secured to prevent misuse.*** Additional books are available from the MDC (material part # 00410-92007).

Please complete the form as shown and provide it to owners of vehicles registered in California.

Vehicle Emission Recall – Proof of Correction

License Number	Make	Year Model	Body Type	Vehicle Identification Number
----------------	------	------------	-----------	-------------------------------

Manufacturer _____ Recall Number _____

The above described vehicle has been repaired, modified and/or equipped with new emission control devices to meet applicable California Emission Control Laws.

Dealer's Name _____ Address, City, State and Zip _____

Date _____ Dealership's Authorized Signature _____

Return this certificate to DMV only when required – otherwise retain for your records. MOC# 00910-92007

Labels and arrows:
- Vehicles License Plate Number points to License Number field.
- Vehicle make (Toyota) points to Make field.
- Vehicle Model Year (i.e. 2004) points to Year Model field.
- Body Type (i.e. Sedan, SUV, Truck) points to Body Type field.
- Full 17 digit VIN points to Vehicle Identification Number field.
- Manufacturer (Toyota) points to Manufacturer field.
- Dealer Information points to Dealer's Name and Address fields.
- Dealer's Signature points to Dealership's Authorized Signature field.
- Recall number points to Recall Number field.

Please review this entire package with your Service and Parts staff to familiarize them with the proper step-by-step procedures required to implement this Special Service Campaign.

Thank you for your cooperation.

TOYOTA MOTOR SALES, U.S.A., INC.

**Special Service Campaign 60I
Certain 2001 Through 2003 Model Year Highlander
Certain 2001 Through 2002 Model Year RAV4
Engine Control Module Reprogramming**

Dear Toyota Customer:

Thank you very much for your patronage of Toyota. We are dedicated to providing vehicles of outstanding quality and value. As part of our continuing efforts to provide superior customer satisfaction, Toyota is announcing a Special Service Campaign Program on certain 2001 through 2003 Model Year 4-cylinder Highlander vehicles and certain 2001 to 2002 Model Year RAV4 vehicles.

What is the problem?

In recent months, Toyota has received reports that some customers may experience a specific Malfunction Indicator Light (check engine light) "ON" condition. Toyota has investigated these concerns and discovered an issue with the program logic in the Engine Control Module (ECM). New program logic has been developed to correct this condition.

What will Toyota do?

Before you are inconvenienced by this condition, Toyota would like to reprogram the ECM in your vehicle. Any Toyota dealer will conduct this service at **NO CHARGE** to you.

What should you do?

Please contact your authorized Toyota dealer to make an appointment to reprogram the program logic in the Engine Control Module (ECM) with improved logic. This can also be done during your next scheduled maintenance. Please inform the dealership of this campaign when you schedule your appointment. The reprogramming will take approximately 30 minutes. However, depending on the dealer's work schedule, it may be necessary to make your vehicle available for a longer period of time.

Please present this notice to the Toyota Dealer when you bring the vehicle in for your service appointment.

If you no longer own the vehicle, please indicate so on the enclosed postage paid form, providing us with the name and address of the new owner.

What if you have other questions?

Your local Toyota dealer will be more than happy to answer any of your questions and set up an appointment to perform the update. If you require further assistance, you may contact the Toyota Customer Experience Center at 1-888-270-9371 Monday through Friday, 5:00 am to 9:30 pm, Saturday and Sunday 7:00 am through 3:00 pm Pacific Standard Time.

What if you live in California and don't have this Special Service Campaign performed?

The State of California requires the completion of Special Service Campaigns on emission related parts prior to vehicle registration renewal. In addition, the State requires that every vehicle must pass an emission test (SMOG Check) every two years and before it is sold.

Without the completion of this no cost Special Service Campaign, your vehicle may be more likely to fail this test. State of California regulations require Toyota to provide the Department of Motor Vehicles with a record of all vehicles that have not had the Special Service Campaign completed.

Your Toyota dealer will provide you with a Vehicle Emissions Recall Proof of Correction Form after the campaign has been completed. Please ensure you retain this form since the DMV may require that you supply proof that the campaign has been completed during your vehicle registration renewal process.

We have sent this notice in the interest of your continued satisfaction with our products, and we sincerely regret any inconvenience this condition may have caused you.

Thank you for driving a Toyota.

Sincerely,

TOYOTA MOTOR SALES, U.S.A., INC.

SAMPLE



**Special Service Campaign (SSC) 60I
Certain 2001 Through 2003 Model Year Highlander (4-cylinder)
Certain 2001 Through 2002 Model Year RAV4
Engine Control Module Reprogramming Q&A**

Q1: What is the condition?

A1: In recent months, Toyota has received reports that some customers may experience a specific Malfunction Indicator Light (check engine light) "ON" condition. Toyota has investigated these concerns and discovered an issue with the program logic in the Engine Control Module (ECM).

Q2: What is the cause of this condition?

A2: This condition is caused by a problem with the program logic in the ECM.

Q3: Are there any warnings that this condition has occurred?

A3: Yes, the Malfunction Indicator Light (check engine light) may illuminate.

Q4: Which and how many vehicles are involved?

A4: There are approximately 60,700 4-cylinder Highlander (2001 through 2003 model year) and 159,100 RAV4 (2001 through 2002 model year) vehicles involved in the U.S.

Q5: What is the production period of the affected vehicles?

A5: The affected vehicles were produced from July 24, 2000 to August 22, 2003.

Q6: Are there any other Toyota or Lexus vehicles involved?

A6: No, this condition only affects 2001 through 2003 4-cylinder Highlander and 2001 through 2002 RAV4 vehicles.

Q7: How many cases of this condition have been reported?

A7: There have been 80 cases of this condition reported in 2001 through 2003 4-cylinder Highlander and 2001 through 2002 RAV4 vehicles.

Q8: What is Toyota going to do?

A8: Owners of the involved vehicles will receive a Special Service Campaign notification by first class mail in mid-December, 2006. Toyota dealers will reprogram the ECM with improved logic at **NO CHARGE** to the customer.

Q9: How long will the repair take?

A9: The reprogramming of the ECM will take approximately 30 minutes. However, depending upon the dealer's work schedule, it may be necessary to make the vehicle available for a longer period of time.

Q10: What should an owner do if they experience the condition?

A10: Owners are requested to contact their local Toyota dealer for diagnosis and repair.

TECHNICAL INSTRUCTIONS

FOR

SPECIAL SERVICE CAMPAIGN 60I

**CERTAIN 2001 THROUGH 2003 MODEL YEAR 4-CYLINDER
HIGHLANDER
AND CERTAIN 2001 THROUGH 2002 MODEL YEAR
RAV4
ENGINE CONTROL MODULE REPROGRAMMING**

I. OPERATION FLOW CHART

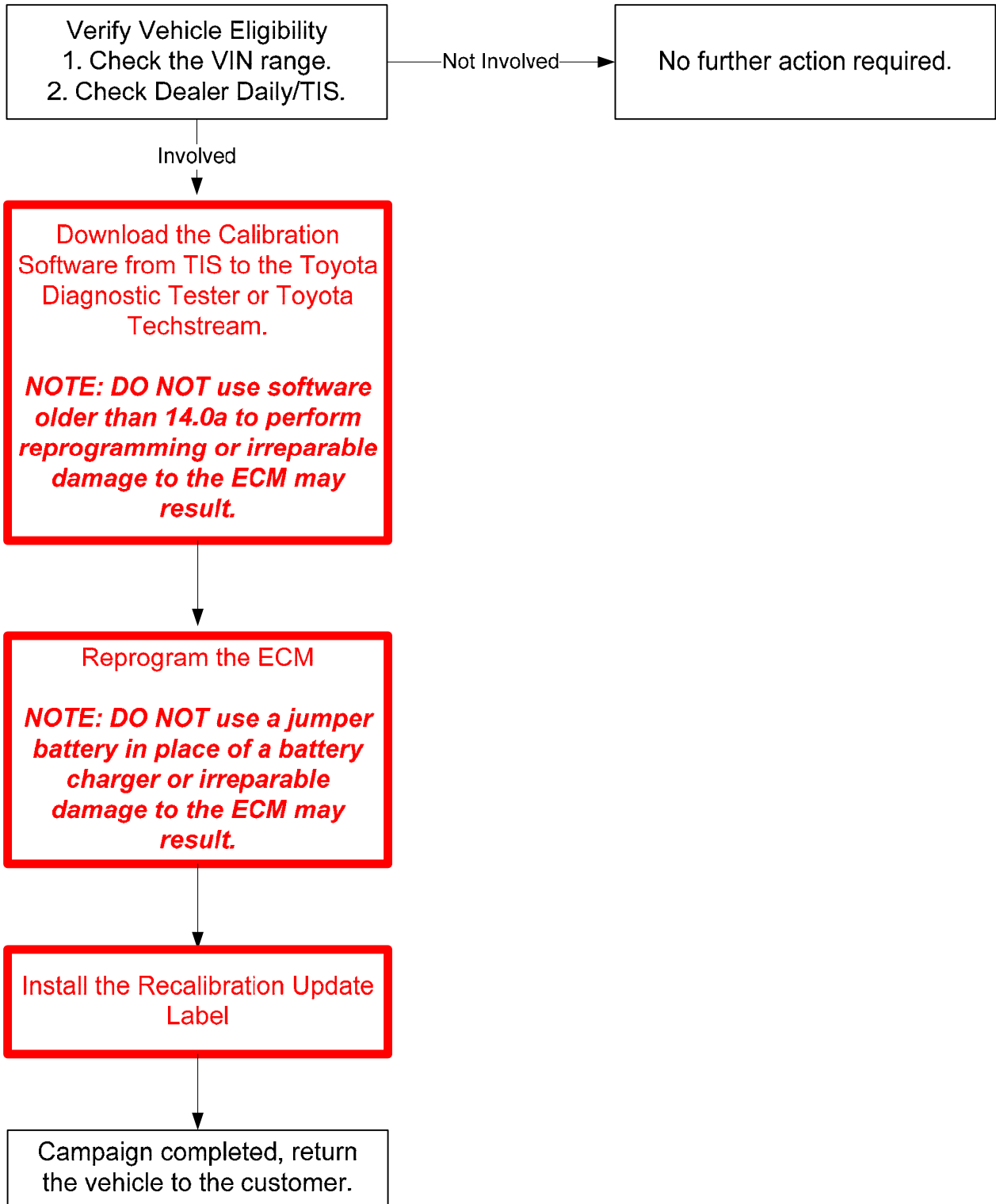

II. IDENTIFICATION OF AFFECTED VEHICLES

A. AFFECTED VIN RANGE

MODEL	MY	VIN Range	
		VDS	Range
Highlander	2001	GD21A	0001024 - 0020971
		HD21A	0001016 - 0010592
	2002	GD21A	0020972 - 0046738
		HD21A	0010594 - 0018656
	2003	GD21A	0046739 - 0073654
		HD21A	0018659 - 0025429
RAV4	2001	GH20V	0001008 - 0041683
		HH20V	0018795 - 0129192 6000000 - 6013768
	2002	GH20V	0040732 - 0078543 6000000 - 6009535
		HH20V	0127491 - 0181148 6012461 - 6066600

NOTE:

- Not all vehicles in the VIN range are affected:
- Check Dealer Daily/TIS to confirm the VIN is involved in this SSC. This will verify the vehicle is affected and has not already been completed prior to dealer shipment or by another dealer.
- TMS warranty will not reimburse dealers for repairs conducted on vehicles that are not affected or were completed by another dealer.

III. PREPARATION

A. PARTS

Parts replacement will **not** be necessary to complete the campaign.

B. TOOLS

- Toyota Diagnostic Tester or Techstream
- Midtronics Battery Tester
- Battery Charger

C. MATERIALS

- TSB: SS002-01

IV. BACKGROUND

In recent months, Toyota has received reports that some customers may experience a Malfunction Indicator Light (check engine light) “ON” condition (P0420 or P0430). Toyota has investigated these concerns and discovered an issue with the program logic in the Engine Control Module (ECM). New program logic has been developed to correct this condition.

V. WORK PROCEDURE



- MAKE SURE TO READ AND FOLLOW ALL SERVICE PRECAUTIONS FOR ECM REPROGRAMMING BEFORE BEGINNING WORK.
- DO NOT USE SOFTWARE OLDER THAN 14.0a FOR REPROGRAMMING OR IRREPARABLE DAMAGE TO THE ECU/ECM MAY RESULT.
- REFERENCE [TSB: SS002-01](#) FOR DETAILED INSTRUCTIONS ON HOW TO DOWNLOAD THE APPROPRIATE CALIBRATION.

A. DOWNLOAD THE NEW CALIBRATION SOFTWARE FROM TIS

Highlander					
Model Year	Engine	Drivetrain		Previous Calibration ID	New Calibration ID
2001-2003	2AZ-FE	2WD		34805000	34811100
				34805100	
				34807000	
				34811000	
		4WD		34806000	34812100
				34806100	
				34808000	
				34812000	

RAV4					
Model Year	Engine	Drivetrain		Previous Calibration ID	New Calibration ID
2001	1AZ-FE	2WD		34205000	34205400
				34205100	
				34205200	
				34205300	
		AT		34207000	34207400
				34207100	
				34207200	
				34207300	
		4WD		34206000	34206400
				34206100	
				34206200	
				34206300	
		AT		34208000	34208400
				34208100	
				34208200	
				34208300	
2002	1AZ-FE	2WD		34218000	34218200
				34218100	
		AT		34220000	34220200
				34220100	
		4WD		34219000	34219200
				34219100	
AT		34221000	34221200		
		34221100			

B. REPROGRAM THE ECM

HIGHLANDER

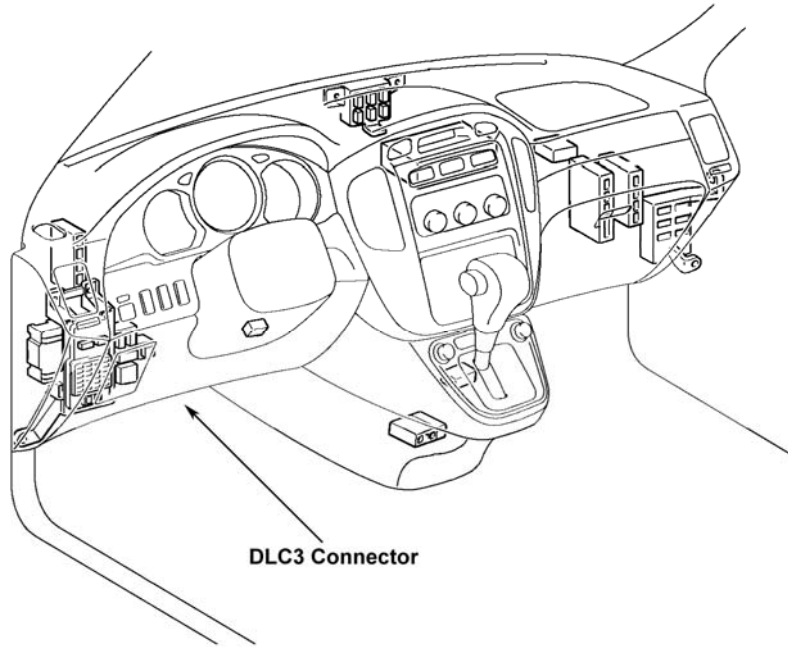

RAV4

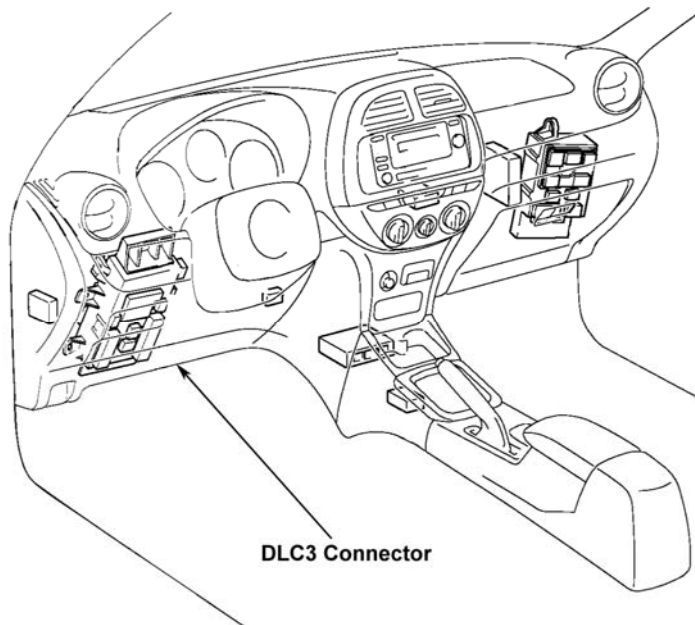

1. REPROGRAMMING PRECAUTIONS



- a) Turn OFF all electrical accessories (i.e. audio systems, dome lamp, air conditioner, etc.) to avoid drops battery voltage while reprogramming the ECU.
- b) Using the Midtronics Battery Tester, confirm that the battery voltage is greater than 11.4 volts.
 - If the voltage is less than 11.4 volts, charge and retest the battery as necessary.
 - The battery must be fully charged before proceeding to the next step.
- c) Connect a battery charger to the vehicle.

NOTE: This MUST be done on all vehicles even if the battery is fully charged.

- d) Set the battery charger to assure that the battery voltage stays consistently above 11.4 volts but **not** more than 16.0 volts.

WARNING:

DO NOT use a jumper battery in place of the battery charger or irreparable damage to the ECM may result.

2. REFERENCE [TSB: SS002-01](#) FOR DETAILED INSTRUCTIONS ON HOW TO PERFORM THE ECM REPROGRAMMING

C. INSTALL THE RECALIBRATION LABEL

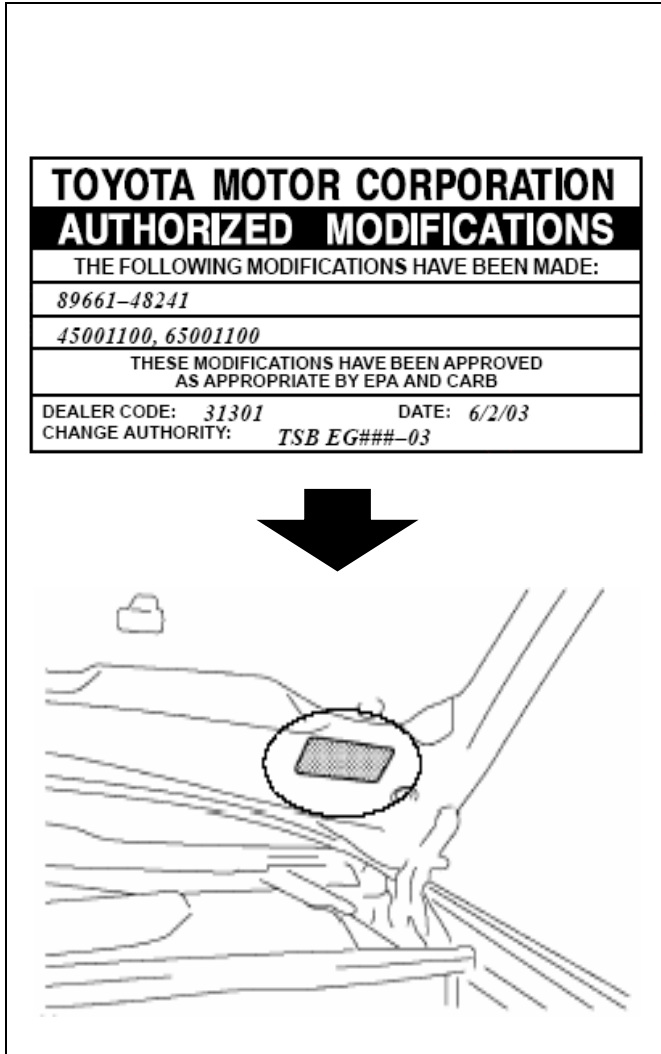

1. RECALIBRATION LABEL INSTALLATION

- a) Using a permanent marker, write the appropriate information on the recalibration label:
- ECU Part Number
 - Calibration Number
 - Dealer Code
 - Repair Date
 - Change Authority
 - Service Campaign No. 60I
- b) Install the Recalibration Label on the underside of the hood in front of the driver (see illustration).

NOTE:

Additional recalibration labels (in packages of 25) can be ordered through the Material Distribution Center (MDC). The Material Number is 00451-00001-LBL.