

# Timing Belt: Service and Repair

## TIMING BELT

### REMOVAL AND INSTALLATION

#### Pre-removal Operation

- Removal of the Under Cover (Front L.H., side L.H.)
- Removal of Front Under Cover Panel <Vehicle with Active Aero>
- Removal of Cruise Control Pump and Link Assembly <Vehicle with Cruise Control>
- Removal of Alternator Assembly  
Suspend the Engine to the Extent of Applied to the Engine Mount

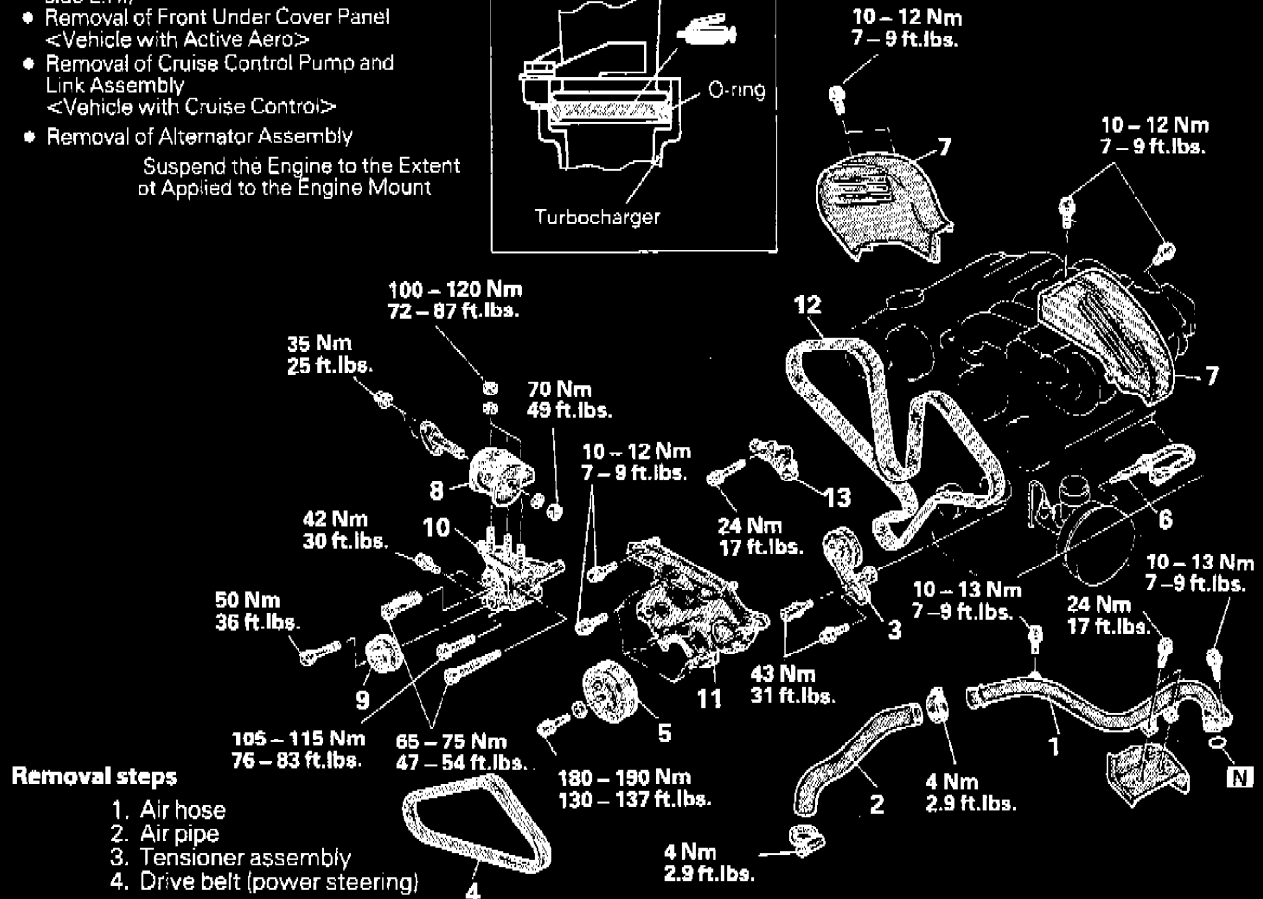
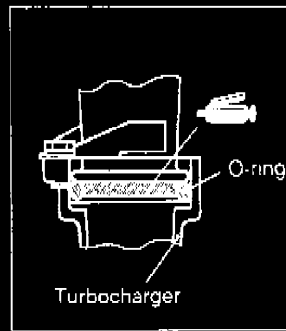

#### Removal steps

1. Air hose
2. Air pipe
3. Tensioner assembly
4. Drive belt (power steering)
5. Crankshaft pulley
6. Brake fluid level sensor
7. Timing belt upper cover
8. Engine mount bracket
9. Idler pulley (alternator / air conditioner)
10. Engine support bracket
11. Timing belt lower cover
- Adjustment of timing belt tension
12. Timing belt
13. Auto tensioner

#### Post-Installation Operation

- Installation of Alternator Assembly
- Installation of the Under Cover (Front L.H., Side L.H.)
- Installation of Front Under Cover Panel <Vehicle with Active Aero>
- Installation of Cruise Control Actuator <Vehicle with Cruise Control>

### SERVICE POINTS OF REMOVAL

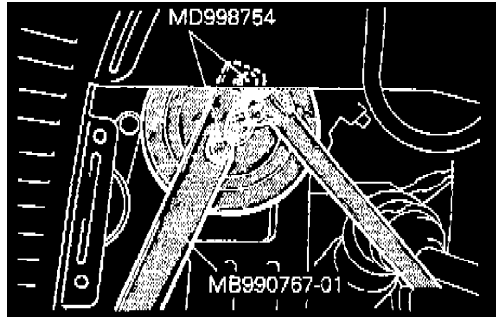

5. Removal of crankshaft pulley.  
Using special tools remove the crankshaft pulley from the crankshaft.

**CAUTION:**

- Use only the specified special tools, or a damaged pulley damper could result.

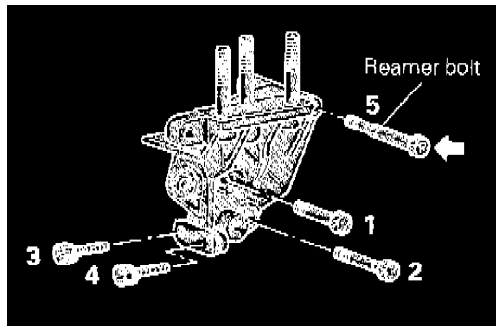

10. Removal of engine support bracket.  
Remove the engine support bracket in the numbered sequence shown in the illustration.  
Spraying lubricant, slowly remove the bolt (reamer bolt) indicated by the arrow.

**CAUTION:**

- Keep in mind that the reamer bolt is sometimes heat seized on the engine support bracket.

12. Removal of timing belt.

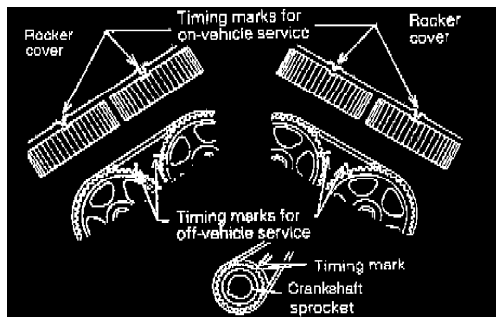

- (a) Align the timing marks.

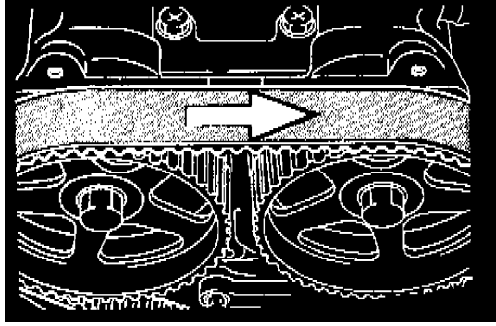

- (b) Make a mark on the back of the timing belt indicating the direction of rotation so it may be reassembled in the same direction it is to be reused.
- (c) Loosen the center bolt on the tensioner pulley to remove the timing belt.

**CAUTION:**

- Water or oil on the belt shorten its life drastically, so the removed timing belt, sprocket, and tensioner must be free from oil and water. These parts should not be washed. Replace parts if seriously contaminated.  
If there is oil or water on each part check the front case oil seals, camshaft oil seal and water pump for leaks.

# TIMING BELT

## REMOVAL AND INSTALLATION

### Pre-removal Operation

- Removal of the Under Cover (Front L.H., side L.H.)
- Removal of Front Under Cover Panel <Vehicle with Active Aero>
- Removal of Cruise Control Pump and Link Assembly <Vehicle with Cruise Control>
- Removal of Alternator Assembly

Suspend the Engine to the Extent of Applied to the Engine Mount

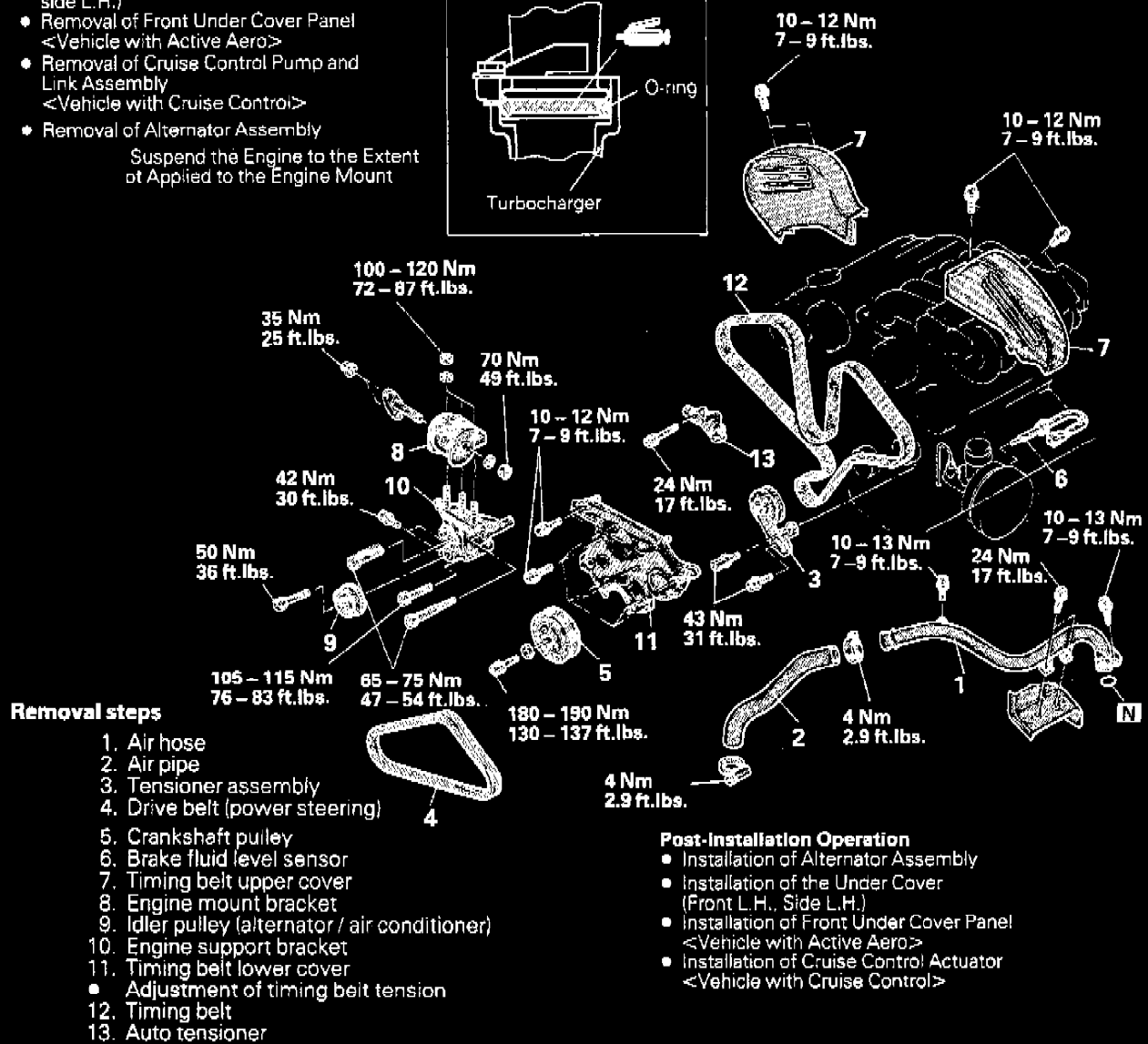
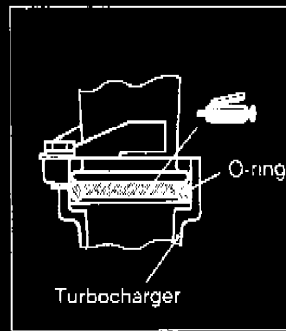

### Removal steps

1. Air hose
2. Air pipe
3. Tensioner assembly
4. Drive belt (power steering)
5. Crankshaft pulley
6. Brake fluid level sensor
7. Timing belt upper cover
8. Engine mount bracket
9. Idler pulley (alternator / air conditioner)
10. Engine support bracket
11. Timing belt lower cover
  - Adjustment of timing belt tension
12. Timing belt
13. Auto tensioner

### Post-Installation Operation

- Installation of Alternator Assembly
- Installation of the Under Cover (Front L.H., Side L.H.)
- Installation of Front Under Cover Panel <Vehicle with Active Aero>
- Installation of Cruise Control Actuator <Vehicle with Cruise Control>

## SERVICE POINTS OF INSTALLATION

13. Installation of auto tensioner.

(a) If the auto tensioner rod is in its fully extended position, reset it as follows:

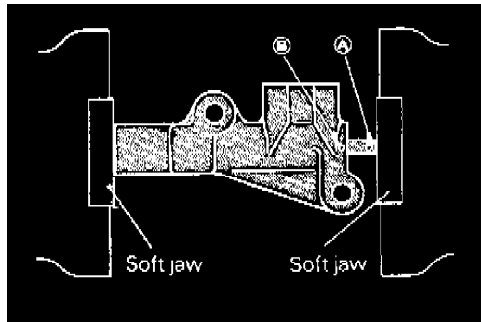

- 1) Keep the auto tensioner level and, in that position. clamp it in the vise with soft jaws.
- 2) Push in the rod little by little with the vise until the set hole (A) in the rod is aligned with that (B) in the cylinder.

**CAUTION:**

- Push in the rod slowly to prevent the push rod from being damaged.

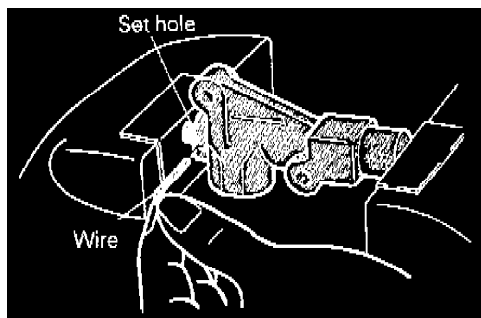

- 3) Insert a wire [1.4 mm (0.055 in.) in diameter] into the set holes.
- 4) Unclamp the auto tensioner from the vise.

- (b) Install the auto tensioner.

**CAUTION:**

- Leave the wire installed in the auto tensioner.

12. Installation of timing belt.

- (a) Align the timing marks on the respective sprockets. In case of the camshaft sprockets in the front bank, proceed as follows:

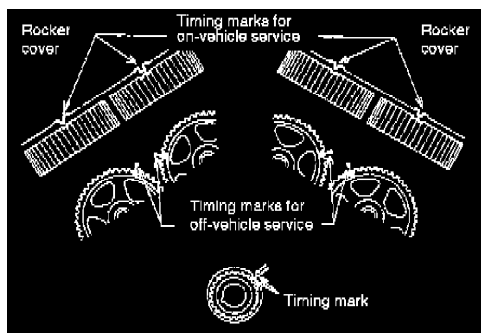

- 1) Install the crankshaft pulley. Shift the timing mark on the crankshaft sprocket by three teeth to lower the piston in No. 1 cylinder slightly from the top dead center on compression stroke.

**CAUTION:**

- Turning the camshaft sprocket with the piston in No.1 cylinder located at TDC on compression stroke may cause the valves to interfere with the piston.

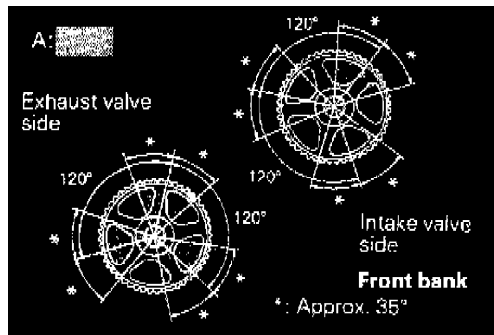

- 2) Make sure that the timing marks on the camshaft sprockets for intake and exhaust valves are not within the range A in the illustration.  
If the timing mark is within range A, turn the camshaft sprocket to move the timing mark to the area closest to the range A.

**CAUTION:**

- In range A, the cam lobe on the camshaft lifts the valve through the rocker arm and the camshaft sprocket is apt to rotate by reaction force of the valve spring. Therefore, be careful not to have the finger pinched between the sprockets.

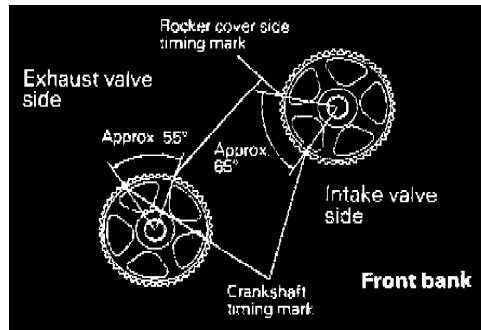

- 3) Turn the camshaft sprocket for either the intake or exhaust valve to locate the timing mark as shown in the illustration. Then turn the other crankshaft to locate the timing mark as shown in the illustration.

**CAUTION:**

- If the intake and exhaust valves of the same cylinder lift simultaneously, interference with each other may result. Therefore, turn the intake valve camshaft sprocket and the exhaust valve camshaft alternately.
- 4) Turn the camshaft sprocket clockwise to align the timing marks.  
If the camshaft sprocket has been turned excessively, turn it counterclockwise to align the timing marks.

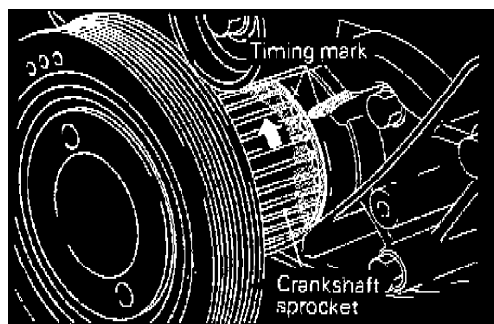

- 5) Align the timing mark of the crankshaft sprocket.

**NOTE:**

- Shift the timing mark of the crankshaft sprocket one teeth in counterclockwise direction to facilitate belt installation.

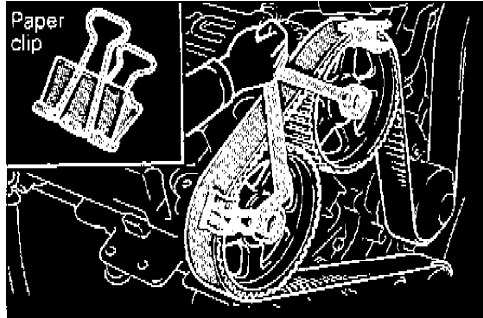
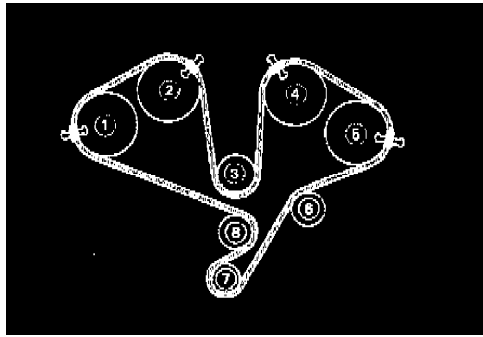

- (b) Using paper clips, install the timing belt in the following order with care not to allow the belt to slack.
1. Exhaust camshaft sprocket (front bank side)
  2. Intake camshaft sprocket (front bank side)
  3. Water pump pulley
  4. Intake camshaft sprocket (rear bank side)
  5. Exhaust camshaft sprocket
  6. Idler pulley
  7. Crankshaft sprocket
  8. Tensioner pulley

**NOTE:**

- Since the camshaft sprockets turn easily, secure them with box wrenches to install the timing belt.

**CAUTION:**

- Be careful, the camshaft is turned by the reaction of valve spring.
- If the timing belt is reused, install it so that the arrow marks made at removal are in the direction of rotation.

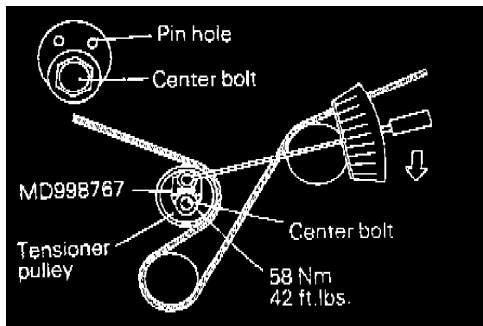

- (c) Turn the tensioner pulley so that its pin holes are located above the center bolt. Then, press the tensioner pulley against the timing belt and, at the same time, temporarily tighten the center bolt.
- (d) Check that the timing marks on all sprockets are aligned properly.
- (e) Remove the four clips.

**ADJUSTMENT OF TIMING BELT TENSION**

- (a) Rotate the crankshaft 1/4 turn counterclockwise, then rotate it clockwise until the timing marks are aligned.
- (b) Loosen the center bolt on the tensioner pulley. Using the special tool and torque wrench, apply tensioning torque to the timing belt and, at the same time; tighten the center bolt to specification.

**Specified torque: 10 Nm (7 ft.lbs.) [Timing belt tensioning torque]**

**CAUTION:**

When tightening the center bolt, make sure that the tensioner pulley is not rotated together.

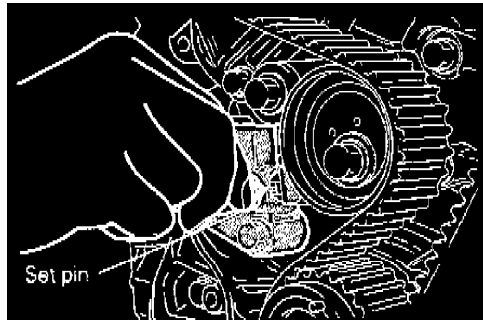

- (c) Remove the set pin from the auto tensioner. At this time, make sure that the set pin can be easily removed.
- (d) Rotate the crankshaft two turns clockwise and leave it as is for five minutes or more. Then, check again that the set pin can be easily removed from, and installed to, the auto tensioner.

**NOTE:**

- Even if the set pin cannot be easily inserted, the auto tensioner is normal if its rod protrusion is within specification.

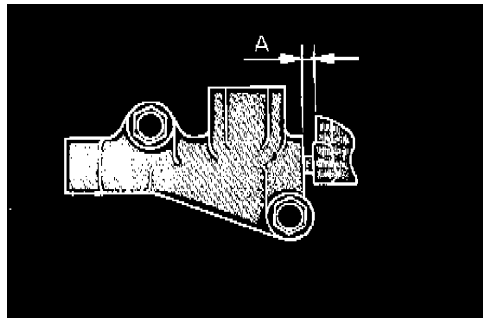

**Standard value (A): 3.8 - 4.5 mm (0.149 - 0.177 in.)**

If the protrusion is out of specification, repeat steps (1) to (4).

- (e) Check again that timing marks on all sprockets are aligned properly.

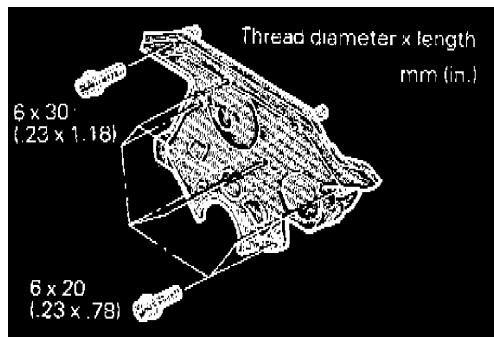

11. Installation of timing belt front cover. (LOWER)

Since the mounting bolts of timing cover are different size depending on location, insert them with care.

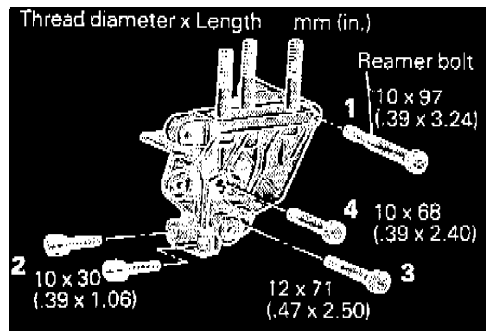

10. Installation of engine support bracket.

Since the mounting bolts of engine support bracket are different in size depending on location, insert them in numbered sequence.

**CAUTION:**

- When installing the reamer bolt, tighten it, slowly spraying lubricant on the reamer area.

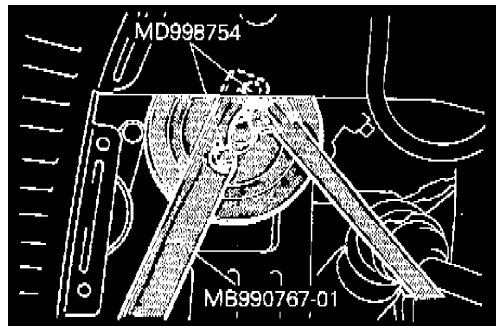

5. Installation of crankshaft pulley.

Using the special tool, attach the crankshaft pulley to the crankshaft.

**CAUTION:**

- Use only the specified special tools, otherwise a damaged pulley damper could result.