

Window Regulator: Technical Service Bulletins

Power Door Window - New Wire Type Subassembly

BODY
BO94-004 (REVISED)
NOVEMBER 18, 1994
SC 400/300, GS 300, ES 300

Title: WIRE TYPE REGULATOR SUBASSEMBLY, POWER DOOR WINDOW

The information contained in this TSB supersedes BO94-004 dated October 21, 1994. The previous TSIB should be discarded.

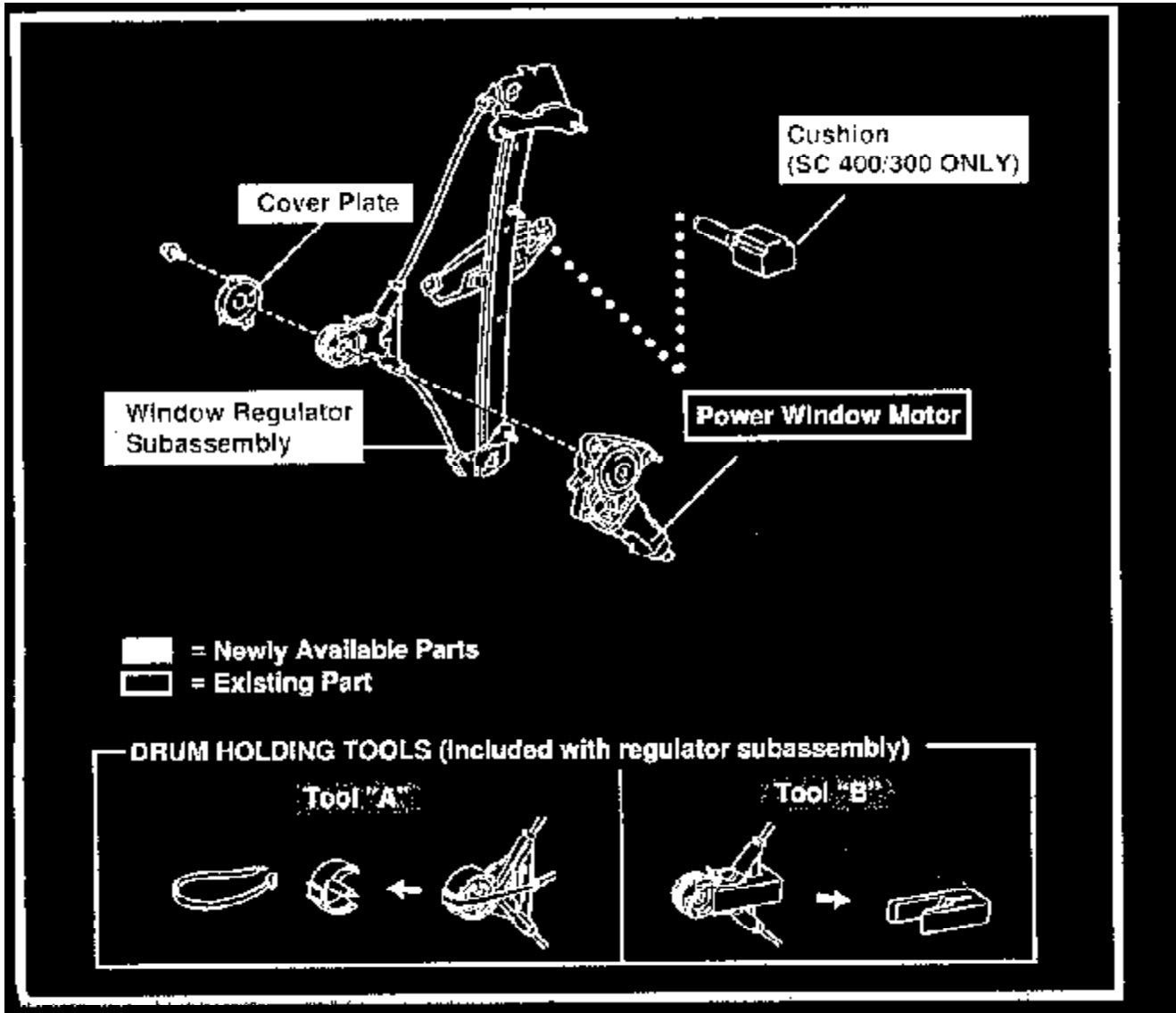

To improve power door window serviceability on SC 400/300, GS 300, and ES 300, a wire regulator subassembly is now available as separate supply parts.

REPAIR PROCEDURES:

- ^ Verify motor operates properly.
- ^ If the motor must be replaced, change the complete regulator assembly.
- ^ If motor operation is correct, replace only the regulator subassembly.

Use the following procedures when replacing the subassembly.

WINDOW REGULATOR DISASSEMBLY:

1. REMOVE COVER PLATE

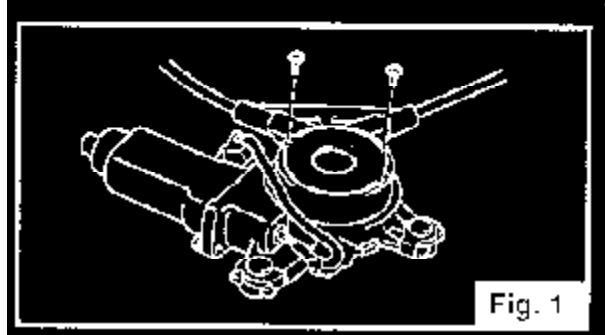

- ^ Remove the two screws and cover plate; see figure 1.

Note:

The screws and cover plate are reusable.

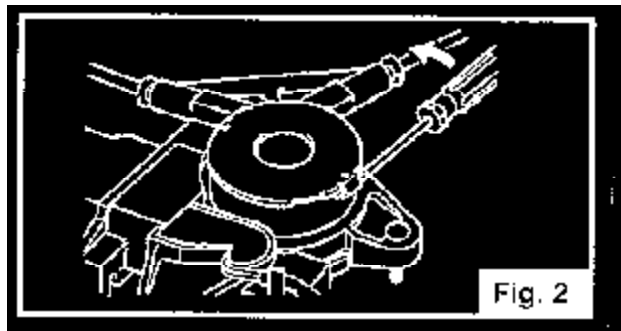

- ^ Pry up the cover plate tab using a small flat-head screwdriver and remove the plate. Use care not to damage the motor housing; see figure 2.

Note:

The cover plate is not reusable.

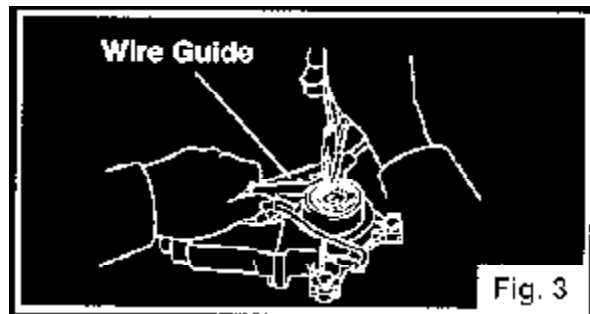

2. REMOVE WINDOW REGULATOR DRUM AND WIRE GUIDE FROM MOTOR HOUSING USING NEEDLE NOSE PLIERS (SEE FIGURE 3).

Caution:

Do not use a flat-head screwdriver to remove the drum and wire guide.

WINDOW REGULATOR INSTALLATION:

1. INSERT THE WINDOW REGULATOR DRUM INTO THE MOTOR HOUSING.

Note:

- ^ To prevent the window regulator drum and cable from coming off, do not tilt the drum, subject it to shocks or use force. If the cable comes off the drum, do not rewind the cable or reuse it. After the window regulator is installed, do not operate it manually (some window regulators do not utilize a stopper).
- ^ Multipurpose grease (P/N OO289-1WG00) should be applied to all moving parts, especially inside the motor housing and sides of the window regulator drum.

Type "A" holding tool

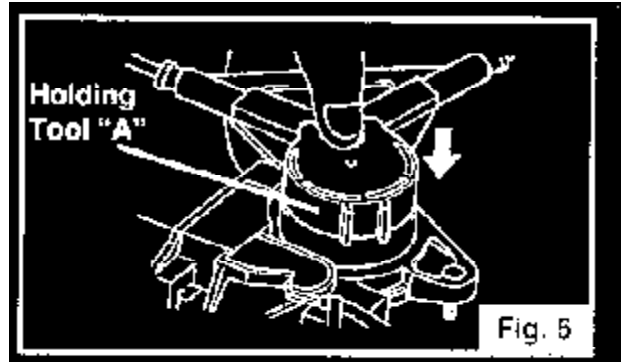

- ^ Apply grease inside the motor housing see Figure 4.

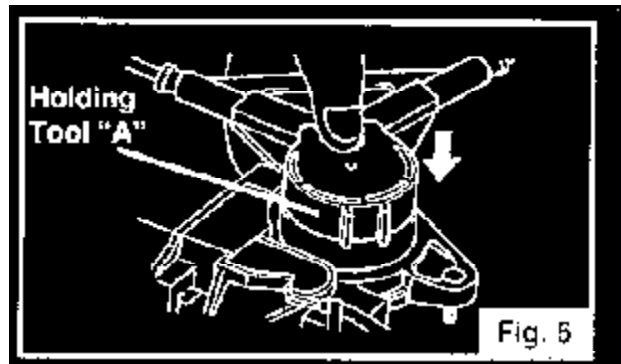

- ^ Using Holding Tool "A", match the holding tool with the motor housing see Figure 5.
- ^ Push down on the wire guide and window regulator while inserting into motor housing see Figure 5.

Note:

If you experience difficulty inserting the window regulator drum into the motor housing, slowly slide the window glass carrier bracket and align the drive shaft of the motor housing with the window regulator drum.

Type "B" holding tool

- ^ Apply grease inside the motor housing see Figure 4.

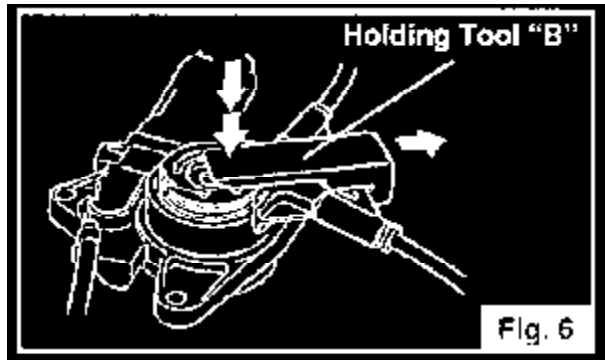

^ Using Holding Tool "B", partially insert the window regulator drum into the motor housing see figure 6.

^ Remove Holding Tool "B" and push the window regulator drum into the motor housing.

Note:

If you are experiencing difficulty inserting the window regulator drum into the motor housing, slowly slide the glass carrier bracket and align the drive shaft of the motor housing with the window regulator drum see figure 5.

^ Apply grease to the sides of the window regulator drum.

2. INSTALL COVER PLATE.

Screw Type Cover Plate

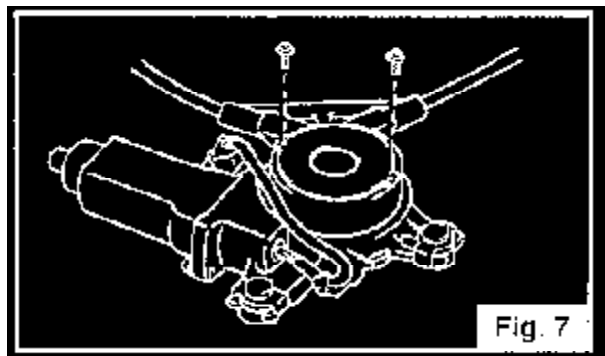

^ Install the original cover plate and screws see figure 7.

Crimped Type Cover Plate

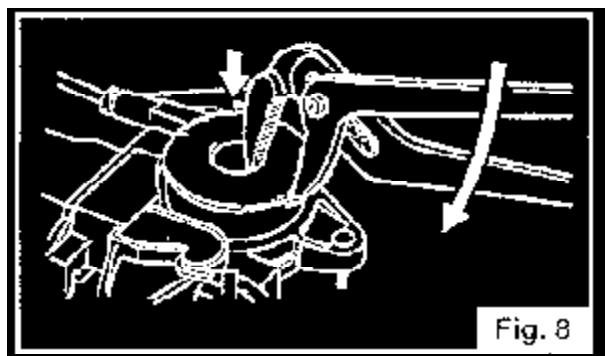

^ Use adjustable pliers to crimp the tab of the cover plate see Figure 8.

Note:

^ Use a new cover plate.

^ Do not hit the cover plate with a hammer, etc.

^ Do not damage the motor housing.

PART NUMBER INFORMATION:

Production Date	Part Name	Part No.
4/91-7/93	Regulator Subassembly Front Door Window RH	69801-24030*
	Regulator Subassembly Front Door Window LH	69802-24030**
7/93-1/94	Regulator Subassembly Front Door Window RH	69801-24031*
	Regulator Subassembly Front Door Window LH	69802-24031**
1/94-	Regulator Subassembly Front Door Window RH	69801-24040
	Regulator Subassembly Front Door Window LH	69802-24040
4/91-	Cover Plate, Window Regulator	69813-32030
	Cushion RH (Included W/Subassembly)	68119-24010
	Cushion LH (Included W/Subassembly)	68119-24020
	Screw	93319-14010

* P/N 69801-24030 is interchangeable with P/N 69801-24031
 ** P/N 69802-24030 is interchangeable with P/N 69802-24031

SC 300/400

Part Name	Part Number
Regulator Subassembly, Front Door Window RH	69801-30190
Regulator Subassembly, Front Door Window LH	69802-30190
Regulator Subassembly, Rear Door Window RH	69803-30190
Regulator Subassembly, Rear Door Window LH	69804-30190
Cover Plate, Front Door Window Regulator***	69811-32040
Cover Plate, Rear Door Window Regulator***	69813-32010

*** Nonreusable crimp type and included with subassembly

GS 300

Part Name	Part No.
Regulator Subassembly Front Door Window RH	69801-32070
Regulator Subassembly Front Door Window LH	69802-32070
Regulator Subassembly Rear Door Window RH	69803-32060
Regulator Subassembly Rear Door Window LH	69804-32060
Cover Plate, Front Door Window Regulator	69811-32050
Cover Plate, Rear Door Window Regulator	69813-32030
Screw	93319-14010

ES 300