

[Select Vehicle](#) | [New TSBs](#) | [Technician's Reference](#)

 Component Search:

1998 Mercedes Benz SL 500 (129.067) V8-5.0L (119.982)

[Vehicle Level](#) → [Body and Frame](#) → [Body Control Systems](#) → [Testing and Inspection](#) → [Testing and Inspection Procedures](#) → [Soft Top, Roll Bar \(ST/RB\) \(Manual Deployment\)](#) → [TP - Test Program](#) → [ETP - Electrical Test Program](#)
[→ Component Locations](#) ←

Component Locations

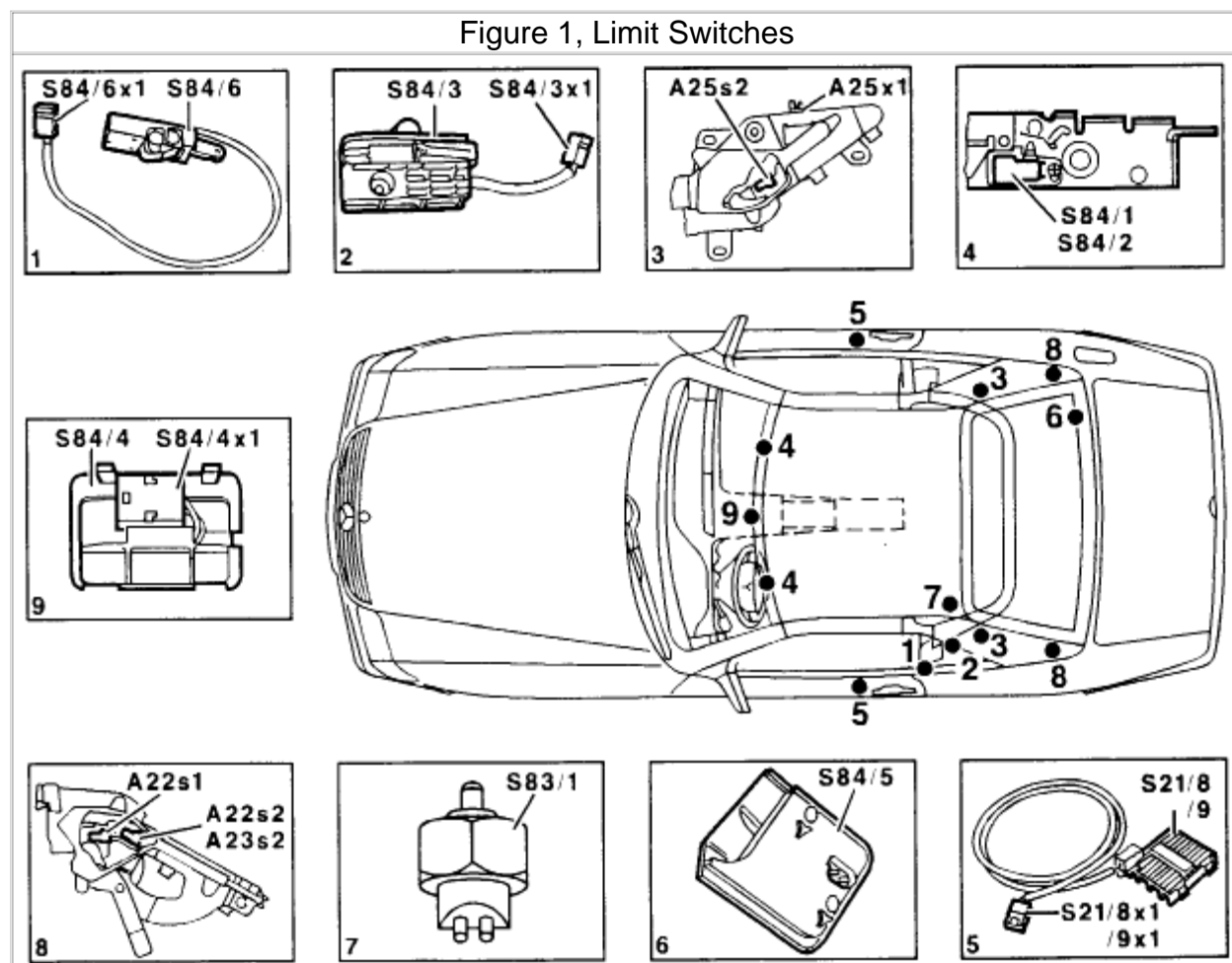
[Notes](#)

A22s1 (8) Bow "closed" switch

A22s2 (8) Bow "locked" switch

A23s2 (8) Bow "locked" switch

- A25s2 (3) Right soft top compartment cover "locked" switch
- S21/8 (5) Right front door "window down" limit switch
- S21/9 (5) Left front door "window down" limit switch
- S83/1 (7) RB "retracted" switch
- S84/1 (4) Left front soft top "locked" switch
- S84/2 (4) Right front soft top "locked" switch
- S84/3 (2) Soft top "open" switch (soft top in storage compartment)
- S84/4 (9) Soft top "closed" switch (reed contact)
- S84/5 (6) Soft top compartment "open" switch
- S84/6 (1) Soft top fabric bow "raised" switch

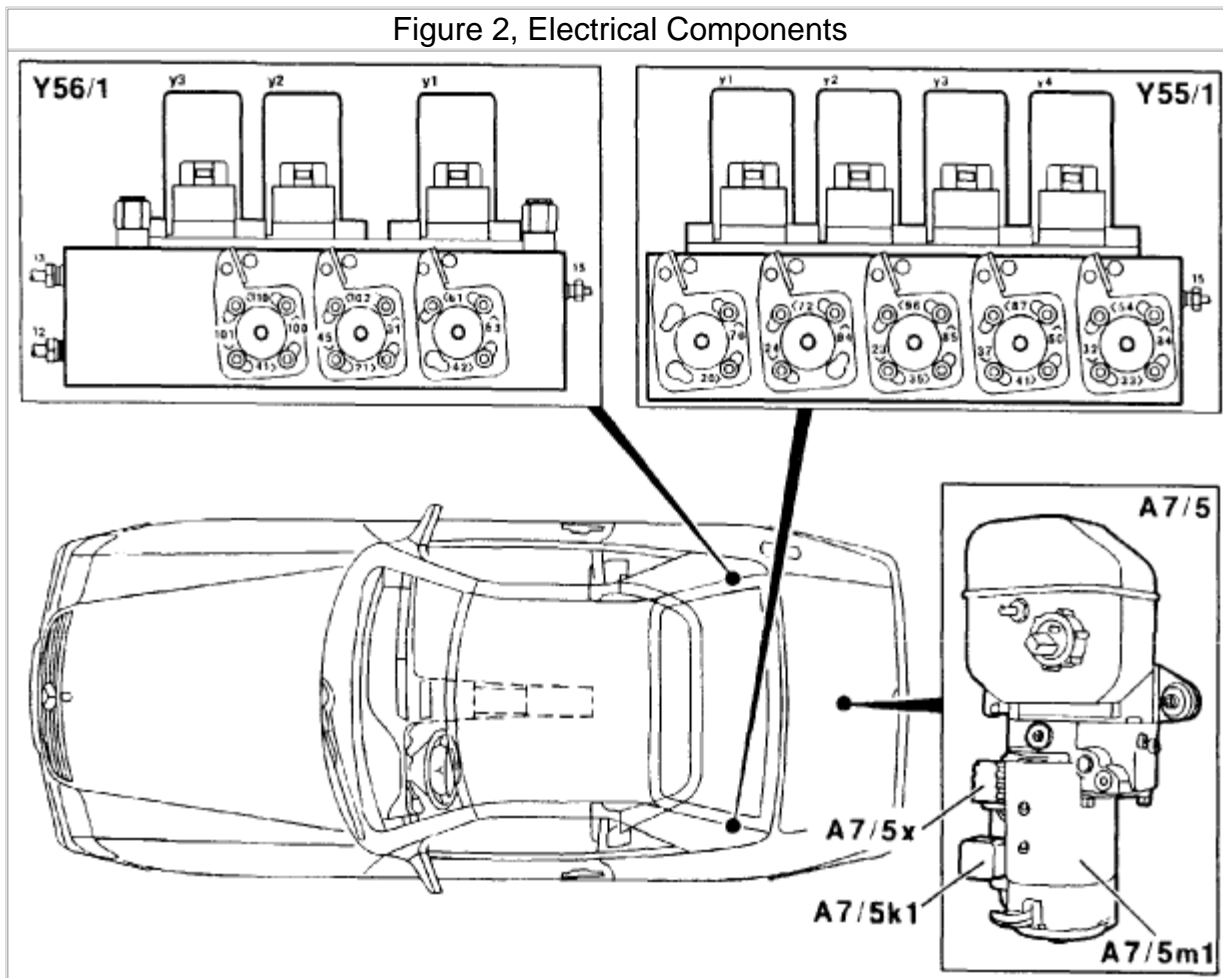

Zoom

Sized for Print

- A7/5 RST/RB hydraulic unit (power soft top)
- A7/5k1 Relay
- A7/5m1 Motor
- A7/5x1 Soft top/roll bar hydraulic unit connector
- Y55/1 Left power soft top valve block (4 connections)
- Y55/1y1 Soft top "closed"/fabric bow lock "open" valve
- Y55/1y2 Fabric bow "closed" valve
- Y55/1y3 Fabric bow "open"/soft top compartment cover "closed" valve
- Y55/1y4 Soft top compartment cover "open"/soft top compartment cover lock "open" valve
- Y56/1 Right power soft top valve block (3 connections)
- Y56/1y1 Soft top "open"/front lock "open" valve
- Y56/1y2 RB "lower" valve
- Y56/1y3 RB "raise" valve

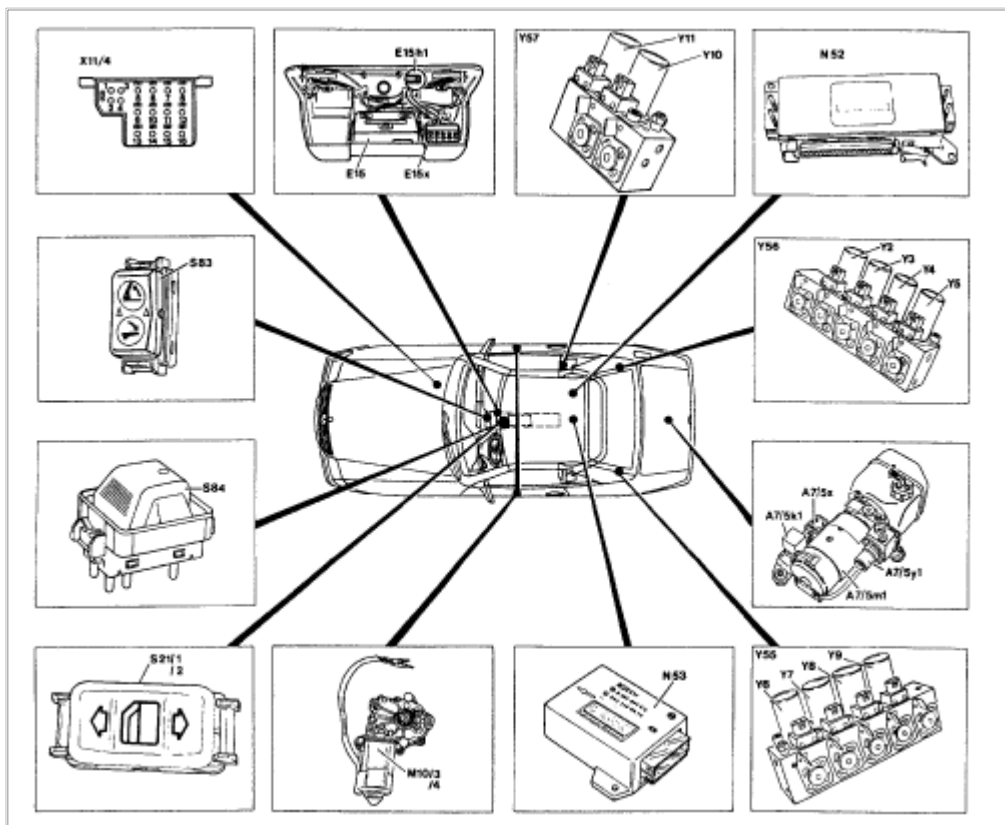

Zoom

Sized for Print

A7/5	Power soft top (roll bar) hydraulic unit
E15h1	Warning buzzer
M10/3	Left front power window motor
M10/4	Right front power window motor
N52	Power soft top control unit
n53	Roll bar control unit
S21/1	left front power window switch
S21/2	Right front power window switch
S83	Roll bar switch (manual operation)
S84	Power soft top switch
X11/4	Test connection for diagnosis (impulse readout, 16-pole)
Y55	left valve block, power soft top (4 connections)
Y56	Right valve block, power soft top (4 connections)
Y57	Valve block, roll bar

Figure 4, Electrical Components

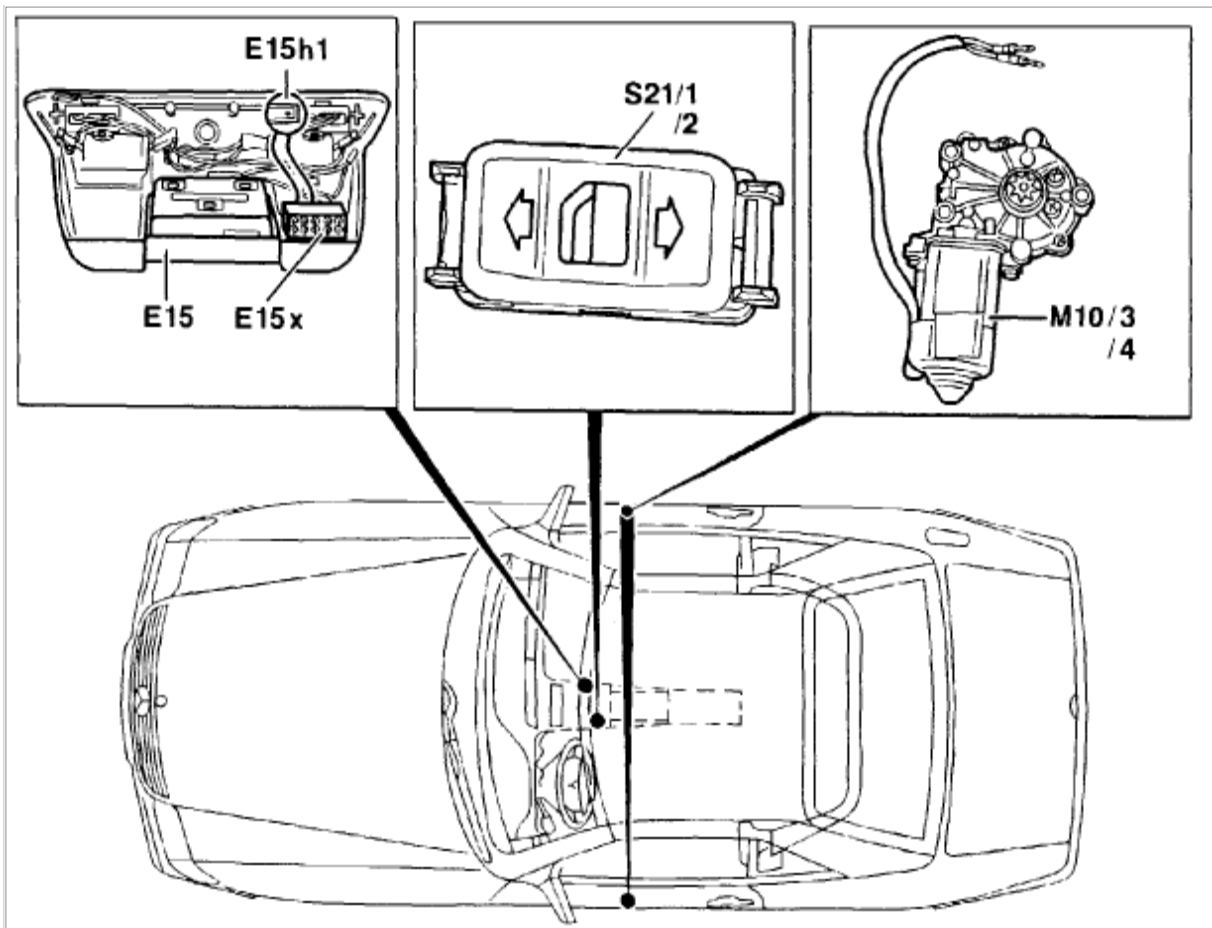

Zoom

Sized for Print

- E15 Dome lamp (with shut-off delay and reading lamp)
- E15h1 Warning buzzer
- E15x1 Done lamp connector (with Shut-off delay and reading lamp)
- M10/3 Left front power window motor
- M10/4 Right front power window motor
- S21/1 Left front power window Switch (front center console)
- S21/2 Right front power window switch (front center console)

Select Vehicle | New TSBs | Technician's Reference

Component Search:

[Conversion Calculator](#)

1998 Mercedes Benz SL 500 (129.067) V8-5.0L (119.982)

[Vehicle Level](#) → [Body and Frame](#) → [Body Control Systems](#) → [Testing and Inspection](#) → [Testing and Inspection Procedures](#) → [Soft Top, Roll Bar \(ST/RB\) \(Manual Deployment\)](#) → [TP - Test Program](#) → [ETP - Electrical Test Program](#) → [Connector Locations](#) ←

Connector Locations

[Notes](#)

Electrical Connector Locations

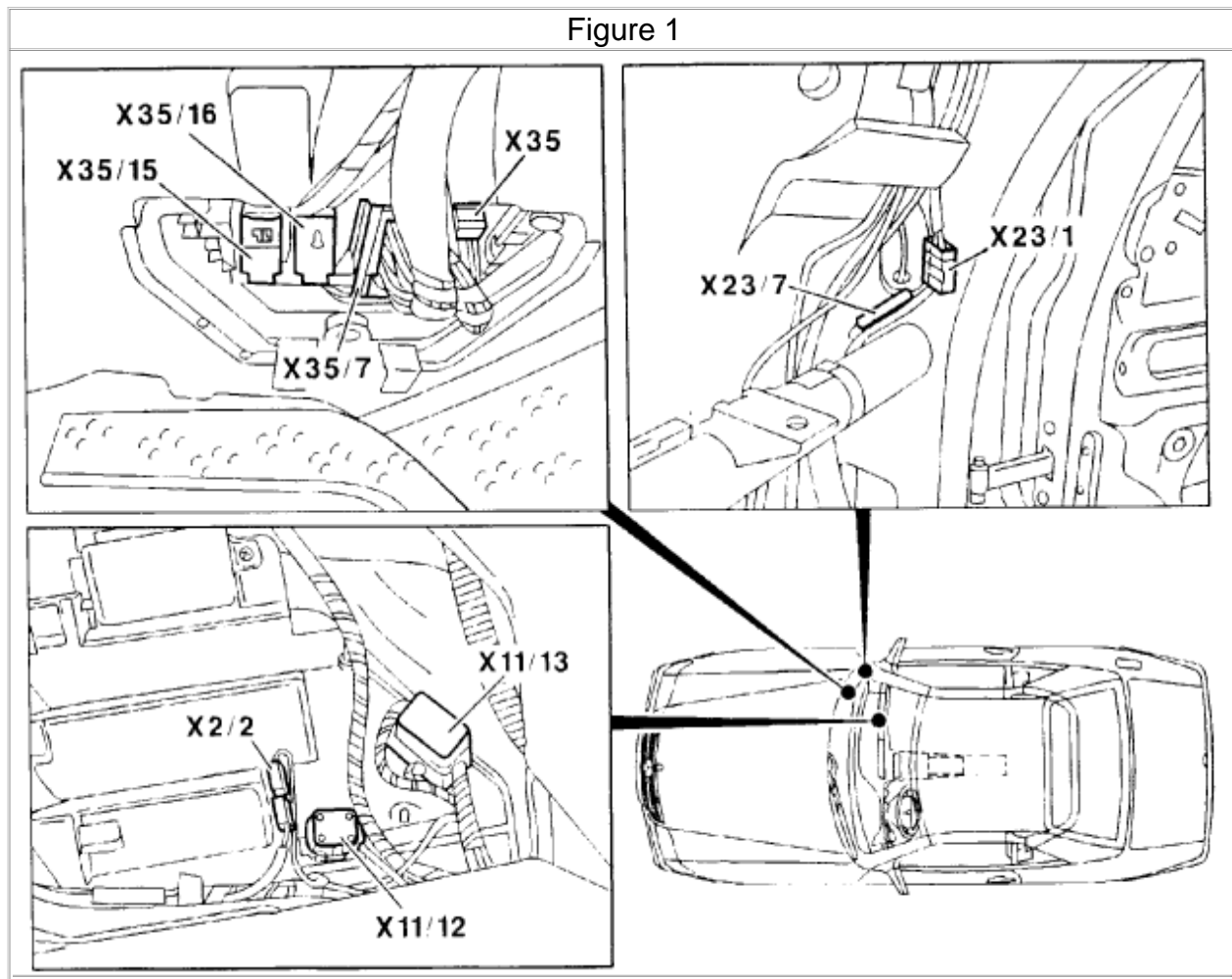

X2/2 VSS connector (radio) (2-pole)

- X11/12 Power soft top test connector (4-pole)
- X23/1 Soft top/front locks connector (3-pole)
- X23/7 Soft top connector (reed contact switch)
- X35 Cockpit/module box separation point (12-pole)
- X35/7 Cockpit/module box separation point (18-pole)
- X35/15 Module box/taillamp harness separation point
- X35/16 Module box/taillamp harness separation point (6 Pole)

© 2008 ALldata LLC. All rights reserved.

[Terms of Use](#)

[Select Vehicle](#) | [New TSBs](#) | [Technician's Reference](#)

 Component Search:
 [Conversion Calculator](#)
1998 Mercedes Benz SL 500 (129.067) V8-5.0L (119.982)

[Vehicle Level](#) → [Body and Frame](#) → [Body Control Systems](#) → [Testing and Inspection](#) → [Testing and Inspection Procedures](#) → [Soft Top, Roll Bar \(ST/RB\) \(Manual Deployment\)](#) → [TP - Test Program](#) → [ETP - Electrical Test Program](#)
 → [Preparation For Test](#) ←

Preparation For Test

[Notes](#)

Preliminary work : Diagnosis Diagnostic Trouble Code (DTC) Memory. [See: DTCM - Diagnostic Trouble Code Memory](#)

- Battery voltage **11 - 14 Volts** (always connect battery charger when working on the soft top).
- Up to 9/95 fuses F1-f6, f8, F20-f1, f2, f3, f4 and f7 in order.
- As of 9/95 fuses F1 -f19, f20, F20-f1, f2, f3, f4, f7, f8 and f9 in order.
- RB control module must release soft top for operation (indicator lamp in RB switch should not blink). If soft top does not release, see impulse counter DTC 5 or HHT 144.

NOTE regarding limit switch testing. Control module in diagnostic mode:

1. Ignition: OFF
2. Bridge sockets 1 and 3 of connector (X11/12) in passenger footwell see Figure 1 (only necessary when testing with socket box). [See: Connector Locations](#)
3. Ignition: ON
4. Remove bridge.

IMPORTANT NOTE

The power soft top control module has 2 different connection possibilities. Therefore, a separation in the section "Test Steps" is necessary.

Connect socket box according to connection diagram X1 (Figure 1):

X1 

Connect socket box according to connection diagram X2 (Figure 2):

X2 

Electrical Wiring Diagrams :

Refer to the applicable Wiring Diagram.

NOTE Regarding Testing With The HHT:

Actual values:

OPEN corresponds to **11 - 14 V** .

CLOSE corresponds to **0 - 1 V** .

As of 9/95

- The RB control module (N53) is integrated into the power soft top control module (N52).
- The hardtop locks front and rear simultaneously.
- The DTC memory can only be read and erased with the HHT.

WARNING: Danger of injury. When disconnecting the connector on the power soft top control module (N52) or when changing the position of control module N52, the [roll bar](#) is deployed !

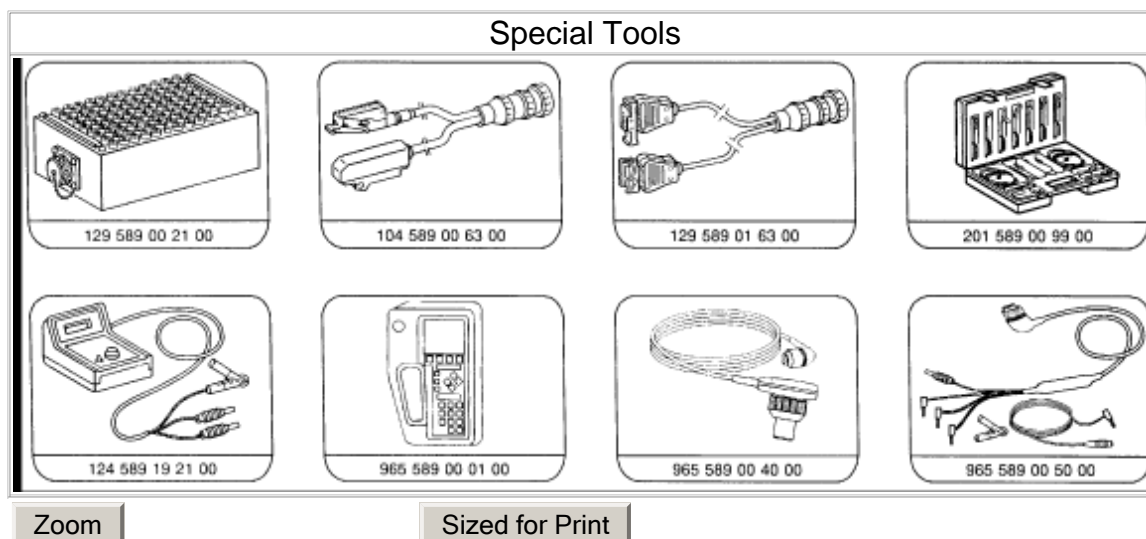

Conventional tools, test equipment

Multimeter Fluke - models 23, 83, 85, 87. Available through the MBNA standard Equipment Program.

Battery Charger.

Connection Diagram - Socket Box to Connector (X1)

Ignition: **OFF**

Disconnect connector X1 from control module.

Connect socket box.

Figure 1

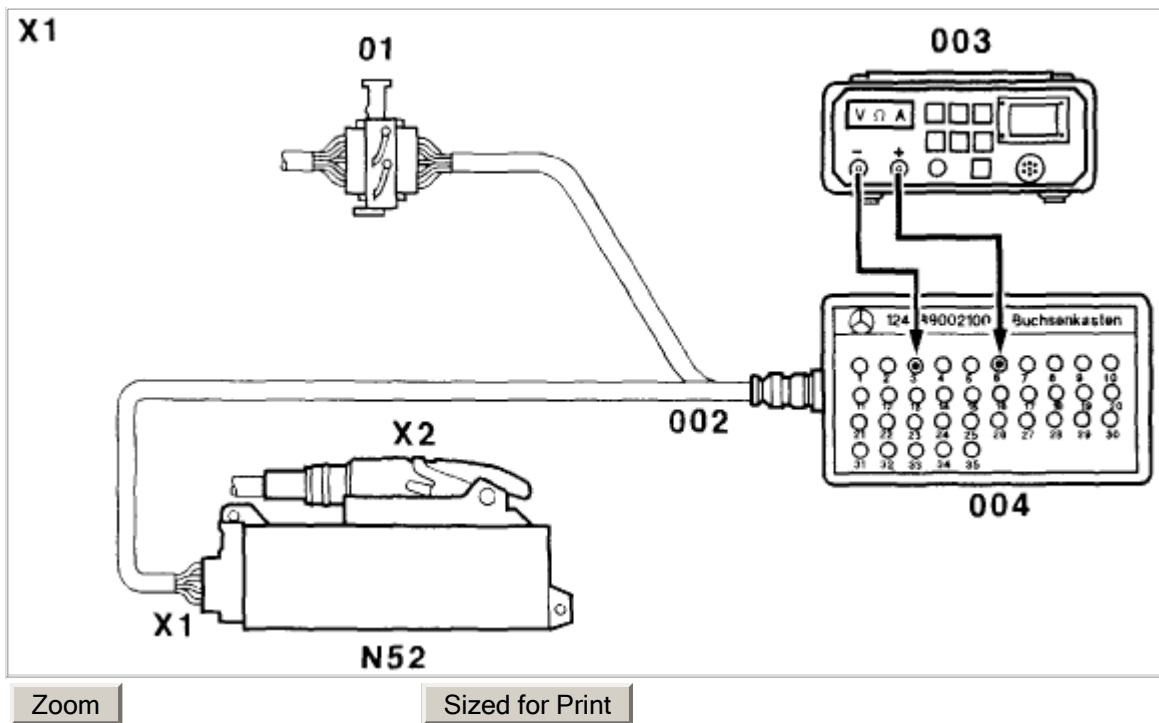

Zoom

Sized for Print

- 01 Connector, 12-pole (vehicle wiring harness)
- 002 Test cable, 12-pole 129 589 01 63 00
- 003 Digital multimeter
- 004 Socket box (35-pole)
- N52 Soft top control module

Connection Diagram - Socket Box to Connector (X2)

Ignition: **OFF**

Disconnect connector X2 from control module.

Connect socket box.

Figure 2

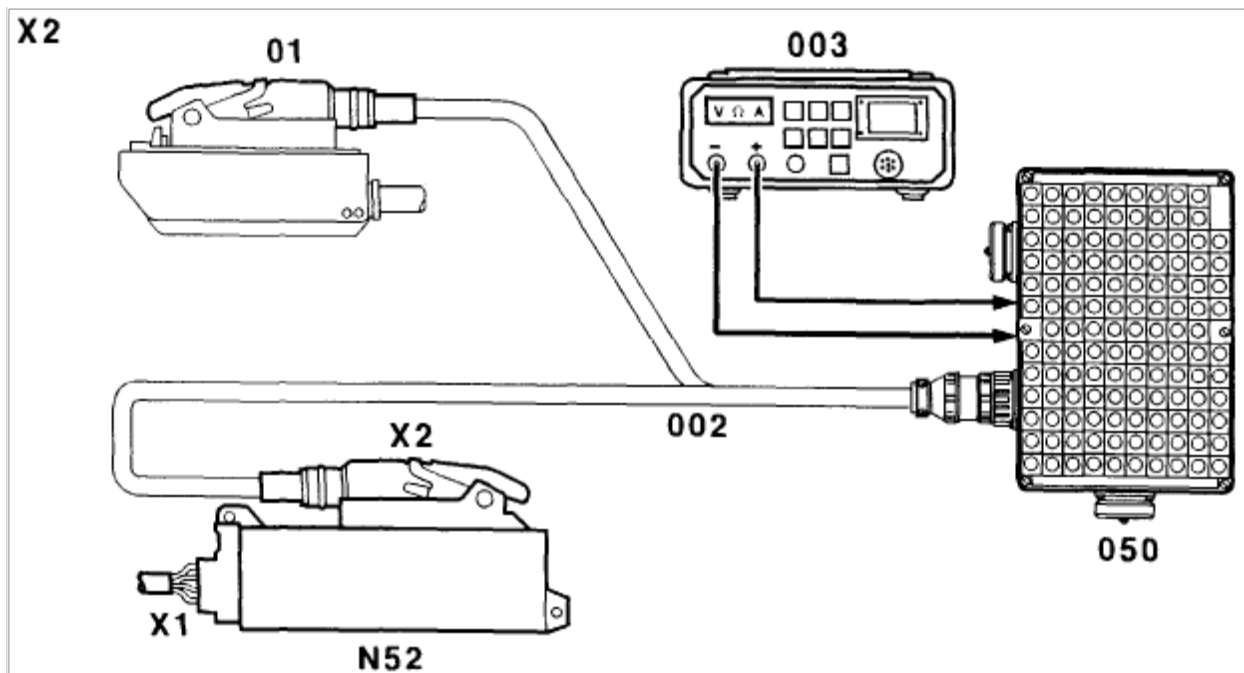
[Zoom](#)[Sized for Print](#)

- 01 Connector, 35-pole (vehicle wiring harness)
- 002 Test cable, 55-pole 104 589 00 63 00
- 003 Digital multimeter
- 004 Socket box (126-pole)
- N52 Soft top control module

© 2008 ALldata LLC. All rights reserved.

[Terms of Use](#)

Select Vehicle | New TSBs | Technician's Reference

Component Search:

Conversion Calculator

1998 Mercedes Benz SL 500 (129.067) V8-5.0L (119.982)









[Vehicle Level](#) → [Body and Frame](#) → [Body Control Systems](#) → [Testing and Inspection](#) → [Testing and Inspection Procedures](#) → [Soft Top, Roll Bar \(ST/RB\) \(Manual Deployment\)](#) → [TP - Test Program](#) → [ETP - Electrical Test Program](#) → [Survey of Electrical Limit Switch Signals](#) ←

Survey of Electrical Limit Switch Signals

[Notes](#)

Limit switches engaged	Soft top compartment cover		Soft top			Fabric bow			Roll bar
	locked	up	locked	closed	up	locked	closed	raised	lowered
When testing with HHT Open corresponds to 11 - 14 V Closed corresponds to 0 - 1 V	A25s2	S84/5	S84/1 S84/2	S84/4	S84/3	A22s2 A23s2	A22s1	S84/6	S83/1
Connection Diagram - Socket Box to Connector (X2) See Preparation For Test, Fig. 2 Control module in diagnostic mode	X2 L 7	X2 L 26	X2 L 30 L 11	X2 L 29	X2 L 46	X2 L 28 L 45	X2 L 8	X2 L 44	X2 L 4
Roll bar retracted, side windows down	0-1 V	11-14 V	0-1 V	0-1 V	11-14 V	0-1 V	0-1 V	11-14 V	0-1 V
Fabric bow unlocked	0-1 V	11-14 V	0-1 V	0-1 V	11-14 V	11-14 V	0-1 V	11-14 V	0-1 V
Fabric bow raise J	0-1 V	11-14 V	0-1 V	0-1 V	11-14 V	11-14 V	11-14 V	0-1 V	0-1 V
Soft top compartment cover unlocked	11-14 V	11-14 V	0-1 V	0-1 V	11-14 V	11-14 V	11-14 V	0-1 V	0-1 V
Soft top compartment cover open	11-14 V	0-1 V	0-1 V	0-1 V	11-14 V	11-14 V	11-14 V	0-1 V	0-1 V
Soft top unlocked in front	11-14 V	0-1 V	11-14 V	0-1 V	11-14 V	11-14 V	11-14 V	0-1 V	0-1 V
Soft top open	11-14 V	0-1 V	11-14 V	11-14 V	11-14 V	11-14 V	11-14 V	0-1 V	0-1 V
Soft top retracted into soft top compartment	11-14 V	0-1 V	11-14 V	11-14 V	0-1 V	11-14 V	11-14 V	0-1 V	0-1 V
Soft top compartment cover locked	0-1 V	11-14 V	11-14 V	11-14 V	0-1 V	11-14 V	11-14 V	0-1 V	0-1 V
Roll bar up, side windows up	0-1 V	11-14 V	11-14 V	11-14 V	0-1 V	11-14 V	11-14 V	0-1 V	11-14 V









Operational Sequence, Opening Soft Top

Limit switches engaged	Soft top compartment cover		Soft top			Fabric bow			Roll bar
	locked	up	locked	closed	open	locked	closed	raised	lowered
When testing with HHT Open corresponds to 11 - 14 V Closed corresponds to 0 - 1 V	A25s2	S84/5	S84/1 S84/2	S84/4	S84/3	A22s2 A23s2	A22s1	S84/6	S83/1
Connection Diagram - Socket Box to Connector (X2) See Preparation For Test, Fig. 2 Control module in diagnostic mode	X2  7	X2  26	X2  30 11	X2  29	X2  46	X2  28 45	X2  8	X2  44	X2  4
Roll bar retracted, side windows down	0-1 V	11-14 V	11-14 V	11-14 V	0-1 V	11-14 V	11-14 V	0-1 V	0-1 V
Soft top compartment cover unlocked	11-14 V	11-14 V	11-14 V	11-14 V	0-1 V	11-14 V	11-14 V	0-1 V	0-1 V
Soft top compartment cover open	11-14 V	0-1 V	11-14 V	11-14 V	0-1 V	11-14 V	11-14 V	0-1 V	0-1 V
Soft top out of soft top compartment	11-14 V	0-1 V	11-14 V	11-14 V	11-14 V	11-14 V	11-14 V	0-1 V	0-1 V
Soft top closed (differential operation)	11-14 V	0-1 V	11-14 V	0-1 V	11-14 V	11-14 V	11-14 V	0-1 V	0-1 V
Soft top locked in front	11-14 V	0-1 V	0-1 V	0-1 V	11-14 V	11-14 V	11-14 V	0-1 V	0-1 V
Soft top compartment cover locked	0-1 V	11-14 V	0-1 V	0-1 V	11-14 V	11-14 V	11-14 V	0-1 V	0-1 V
Fabric bow closed	0-1 V	11-14 V	0-1 V	0-1 V	11-14 V	11-14 V	0-1 V	11-14 V	0-1 V
Fabric bow locked	0-1 V	11-14 V	0-1 V	0-1 V	11-14 V	0-1 V	0-1 V	11-14 V	0-1 V
Roll bar up, side windows up	0-1 V	11-14 V	0-1 V	0-1 V	11-14 V	0-1 V	0-1 V	11-14 V	11-14 V

Zoom

Sized for Print









Operational Sequence, Closing Soft Top

Limit switches engaged	Soft top compartment cover		Soft top			Fabric bow			Roll bar
	locked	up	locked	closed	up	locked	closed	raised	lowered
When testing with HHT Open corresponds to 11 - 14 V Closed corresponds to 0 - 1 V	A25s2	S84/5	S84/1 S84/2	S84/4	S84/3	A22s2 A23s2	A22s1	S84/6	S83/1
Connection Diagram - Socket Box to Connector (X2) See Preparation For Test, Fig. 2 Control module in diagnostic mode	X2  7	X2  26	X2  30 11	X2  29	X2  46	X2  28 45	X2  8	X2  44	X2  4
rear	0-1 V	11-14 V	11-14 V	11-14 V	0-1 V	0-1 V	0-1 V	0-1 V	0-1 V
front	0-1 V	11-14 V	0-1 V	11-14 V	0-1 V	0-1 V	0-1 V	0-1 V	0-1 V

Zoom

Sized for Print

Operational Sequence, Hardtop Locking

Limit switches engaged	Soft top compartment cover		Soft top			Fabric bow			Roll bar
	locked	up	locked	closed	up	locked	closed	raised	lowered
When testing with HHT Open corresponds to 11 - 14 V Closed corresponds to 0 - 1 V	A25s2	S84-5	S84-1 S84-2	S84-4	S84-3	A22s2 A23s2	A22s1	S84-6	S83-1
Connection Diagram - Socket Box to Connector (X2) See Preparation for Test, Fig. 2 Control module in diagnostic mode	X2  7	X2  26	X2  30 11	X2  29	X2  46	X2  28 45	X2  8	X2  44	X2  4
front	0-1 V	11-14 V	11-14 V	11-14 V	0-1 V	0-1 V	0-1 V	0-1 V	0-1 V
rear	0-1 V	11-14 V	11-14 V	11-14 V	0-1 V	11-14 V	0-1 V	0-1 V	0-1 V

Zoom

Sized for Print

Operational Sequence, Hardtop Unlocking

Select Vehicle | New TSBs | Technician's Reference

Component Search:

Conversion Calculator

1998 Mercedes Benz SL 500 (129.067) V8-5.0L (119.982)

[Vehicle Level](#) → [Body and Frame](#) → [Body Control Systems](#) → [Testing and Inspection](#) → [Testing and Inspection Procedures](#) → [Soft Top, Roll Bar \(ST/RB\) \(Manual Deployment\)](#) → [TP - Test Program](#) → [ETP - Electrical Test Program](#) → [Survey of Electrical Valve Actuation](#) ←

Survey of Electrical Valve Actuation

[Notes](#)

Y55/1 Left Power Soft Top Valve Block (4 connections)

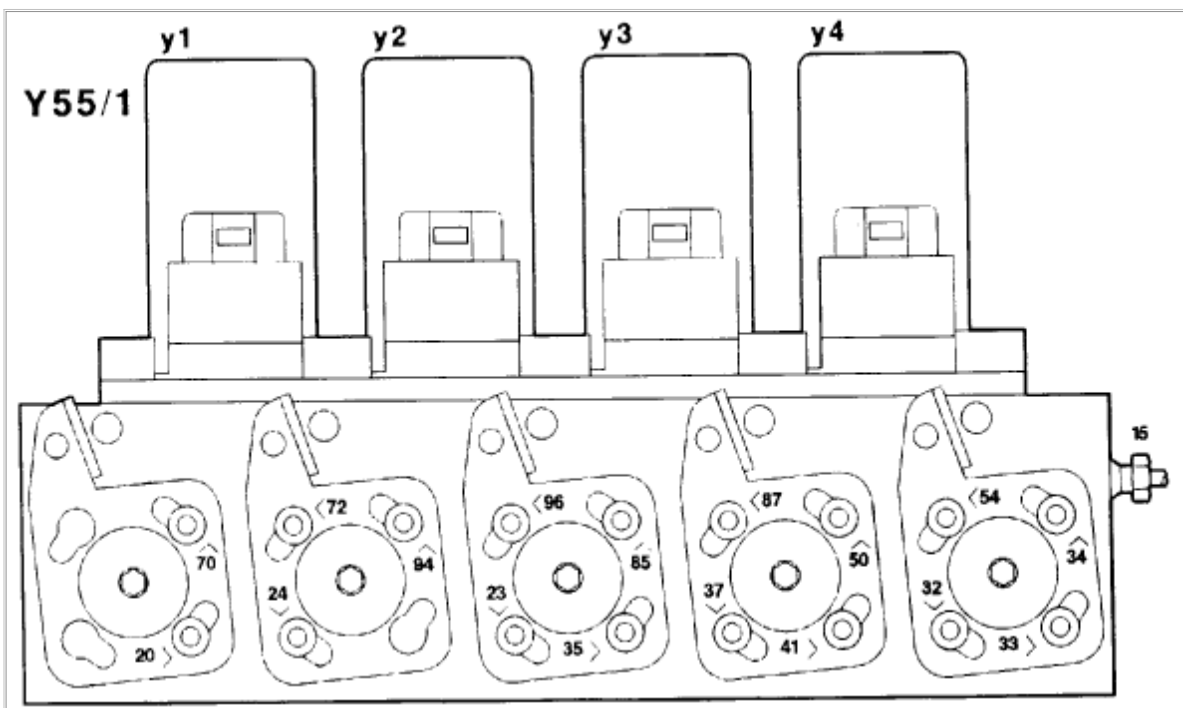

Figure 1

- y1 Soft top "closed"/fabric bow lock "open" valve
- y2 Fabric bow "closed" valve
- y3 Fabric bow "open"/soft top compartment cover "closed" valve
- y4 Soft top compartment cover "open"/soft top compartment cover lock "open" valve

Y56/1 Left Power Soft Top Valve Block (3 connections)

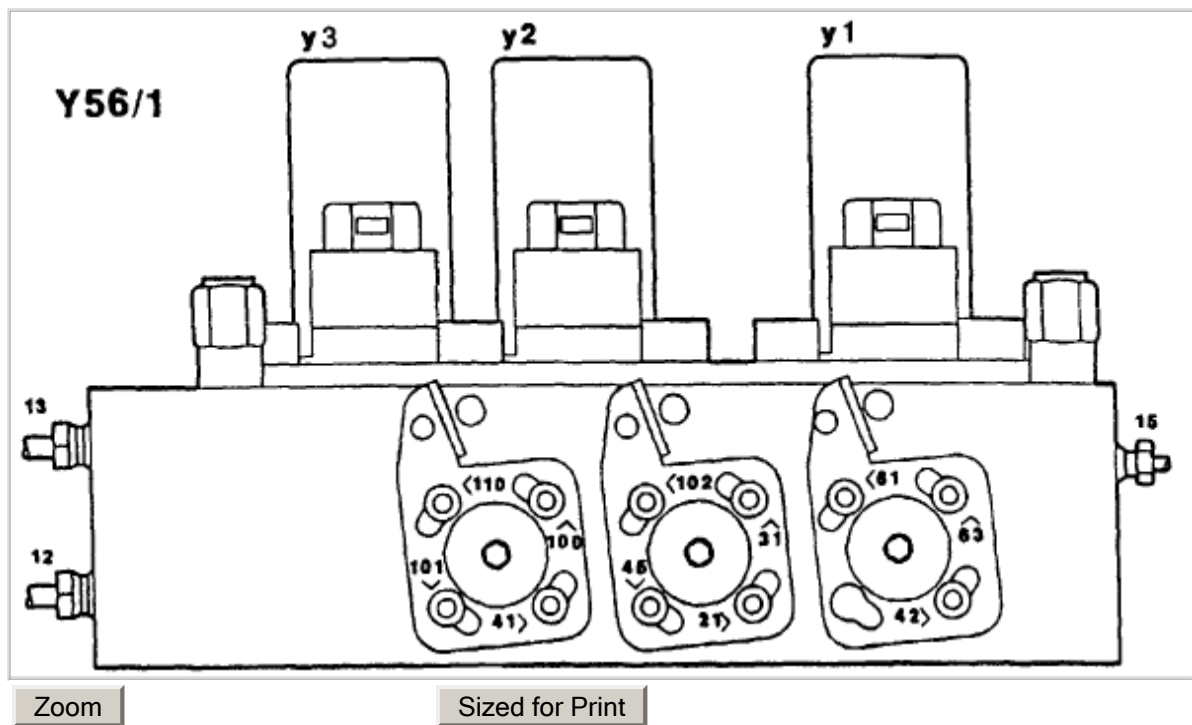

Figure 2

- y1 Soft top "open"/front lock "open" valve
- y2 [Roll bar](#) "lower" valve
- y3 [Roll bar](#) "raise" valve

Valves being controlled at time of operational sequence	Left power soft top valve block (Y55/1)				Right power soft top valve block (Y56/1)		
	Soft top compartment cover "open" / soft top compartment cover lock "open" valve (y4)	Soft top "closed" / fabric bow lock "open" valve (y1)	Fabric bow "closed" valve (y2)	Fabric bow "open" / soft top compartment cover "closed" valve (y3)	Soft top "open" / front lock "open" valve (y1)	Roll bar "raise" valve (y3)	Roll bar "lower" valve, Hydraulic actuator (y2)
When testing with HHT Up corresponds to 11 - 14 V Closed corresponds to 0 - 1 V							
Connection Diagram - Socket Box to Connector (X2), see Preparation For Test Figure 2.	X2 37	X2 36	X2 55	X2 18	X2 19	X2 17	X2 54
Lower roll bar, lower side windows	0-1 V	0-1 V	0-1 V	0-1 V	0-1 V	0-1 V	11-14 V
Unlock fabric bow	0-1 V	11-14 V	0-1 V	0-1 V	0-1 V	0-1 V	11-14 V
Raise fabric bow	0-1 V	11-14 V	0-1 V	11-14 V	0-1 V	0-1 V	11-14 V
Unlock, open soft top compartment cover	11-14 V	0-1 V	0-1 V	11-14 V	0-1 V	0-1 V	11-14 V
Unlock front soft top	11-14 V	11-14 V	0-1 V	11-14 V	11-14 V	0-1 V	11-14 V
Open soft top	11-14 V	0-1 V	0-1 V	11-14 V	11-14 V	0-1 V	11-14 V
Lower soft top in soft top compartment	11-14 V	0-1 V	0-1 V	11-14 V	11-14 V	0-1 V	11-14 V
Close, lock soft top compartment cover	0-1 V	0-1 V	0-1 V	11-14 V	11-14 V	0-1 V	11-14 V
Raise roll bar, raise side windows	0-1 V	0-1 V	0-1 V	0-1 V	0-1 V	11-14 V	11-14 V

Zoom

Sized for Print







Operational Sequence, Soft Top Opening

Valves being controlled at time of operational sequence	Left power soft top valve block (Y55/1)				Right power soft top valve block (Y56/1)		
	Soft top compartment cover "open" / soft top compartment cover lock "open" valve (y4)	Soft top "closed" / fabric bow lock "open" valve (y1)	Fabric bow "closed" valve (y2)	Fabric bow "open" / soft top compartment cover "closed" valve (y3)	Soft top "open" / front lock "open" valve (y1)	Roll bar "raise" valve (y3)	Roll bar "lower" valve, Hydraulic actuator (y2)
When testing with HHT Up corresponds to 11 - 14 V Closed corresponds to 0 - 1 V							
Connection Diagram - Socket Box to Connector (X2), see Preparation For Test Figure 2.	X2 37	X2 36	X2 55	X2 18	X2 19	X2 17	X2 54
Lower roll bar, lower side windows	0-1 V	0-1 V	0-1 V	0-1 V	0-1 V	0-1 V	11-14 V
Unlock, open soft top compartment cover	11-14 V	0-1 V	0-1 V	11-14 V	0-1 V	0-1 V	11-14 V
Close soft top	11-14 V	11-14 V	0-1 V	11-14 V	0-1 V	0-1 V	11-14 V
Close soft top (Differential operation, after approximately 6 seconds)	11-14 V	11-14 V	0-1 V	11-14 V	11-14 V	0-1 V	11-14 V
Lock front soft top (Activate for 0.5 seconds)	11-14 V	0-1 V	0-1 V	11-14 V	0-1 V	0-1 V	0-1 V
Lock front soft top	11-14 V	11-14 V	0-1 V	11-14 V	0-1 V	0-1 V	11-14 V
Close, lock soft top compartment cover	0-1 V	11-14 V	0-1 V	11-14 V	0-1 V	0-1 V	11-14 V
Lower fabric bow	0-1 V	11-14 V	11-14 V	0-1 V	0-1 V	0-1 V	11-14 V
Lock fabric bow	0-1 V	0-1 V	11-14 V	0-1 V	0-1 V	0-1 V	11-14 V
Raise roll bar, raise side windows	0-1 V	0-1 V	0-1 V	0-1 V	0-1 V	11-14 V	11-14 V

Zoom

Sized for Print







Operational Sequence, Soft Top Closing

Valves being controlled at time of operational sequence	Left power soft top valve block (Y55/1)				Right power soft top valve block (Y56/1)		
	Soft top compartment cover "open" / soft top compartment cover lock "open" valve (y4)	Soft top "closed" / fabric bow lock "open" valve (y1)	Fabric bow "open" / soft top compartment cover "closed" valve (y3)	Fabric bow "closed" valve (y2)	Soft top "open" / front lock "open" valve (y1)	Roll bar "raise" valve (y3)	Roll bar "lower" valve, Hydraulic actuator (y2)
When testing with HHT Up corresponds to 11 - 14 V Closed corresponds to 0 - 1 V							
Connection Diagram - Socket Box to Connector (X2), see Preparation For Test Figure 2.	X2  37	X2  36	X2  18	X2  55	X2  19	X2  17	X2  54
Hardtop attached (for approximately 3 seconds)	0-1 V	11-14 V	0-1 V	0-1 V	11-14 V	0-1 V	11-14 V
front	0-1 V	0-1 V	0-1 V	0-1 V	11-14 V	0-1 V	11-14 V
rear	0-1 V	0-1 V	0-1 V	0-1 V	0-1 V	0-1 V	11-14 V

Zoom

Sized for Print

Operational Sequence, Hardtop Locking

Valves being controlled at time of operational sequence	Left power soft top valve block (Y55/1)				Right power soft top valve block (Y56/1)		
	Soft top compartment cover "open" / soft top compartment cover lock "open" valve (y4)	Soft top "closed" / fabric bow lock "open" valve (y1)	Fabric bow "open" / soft top compartment cover "closed" valve (y3)	Fabric bow "closed" valve (y2)	Soft top "open" / front lock "open" valve (y1)	Roll bar "raise" valve (y3)	Roll bar "lower" valve, Hydraulic actuator (y2)
When testing with HHT Up corresponds to 11 - 14 V Closed corresponds to 0 - 1 V							
Connection Diagram - Socket Box to Connector (X2), see Preparation For Test Figure 2.	X2  37	X2  36	X2  18	X2  55	X2  19	X2  17	X2  54
front	0-1 V	0-1 V	0-1 V	0-1 V	11-14 V	0-1 V	11-14 V
rear	0-1 V	11-14 V	0-1 V	0-1 V	11-14 V	0-1 V	11-14 V
Hardtop unlocks (for approximately 3 seconds, after switch is released)	0-1 V	11-14 V	0-1 V	0-1 V	11-14 V	0-1 V	0-1 V

Zoom

Sized for Print

Operational Sequence, Hardtop Unlocking

[Terms of Use](#)

Select Vehicle | New TSBs | Technician's Reference

Component Search:

[Conversion Calculator](#)

1998 Mercedes Benz SL 500 (129.067) V8-5.0L (119.982)

[Vehicle Level](#) → [Body and Frame](#) → [Body Control Systems](#) → [Testing and Inspection](#) → [Testing and Inspection Procedures](#) → [Soft Top, Roll Bar \(ST/RB\) \(Manual Deployment\)](#) → [TP - Test Program](#) → [HTP - Hydraulic Test Program](#)
→ [Component Locations](#) ←

Component Locations

[Notes](#)

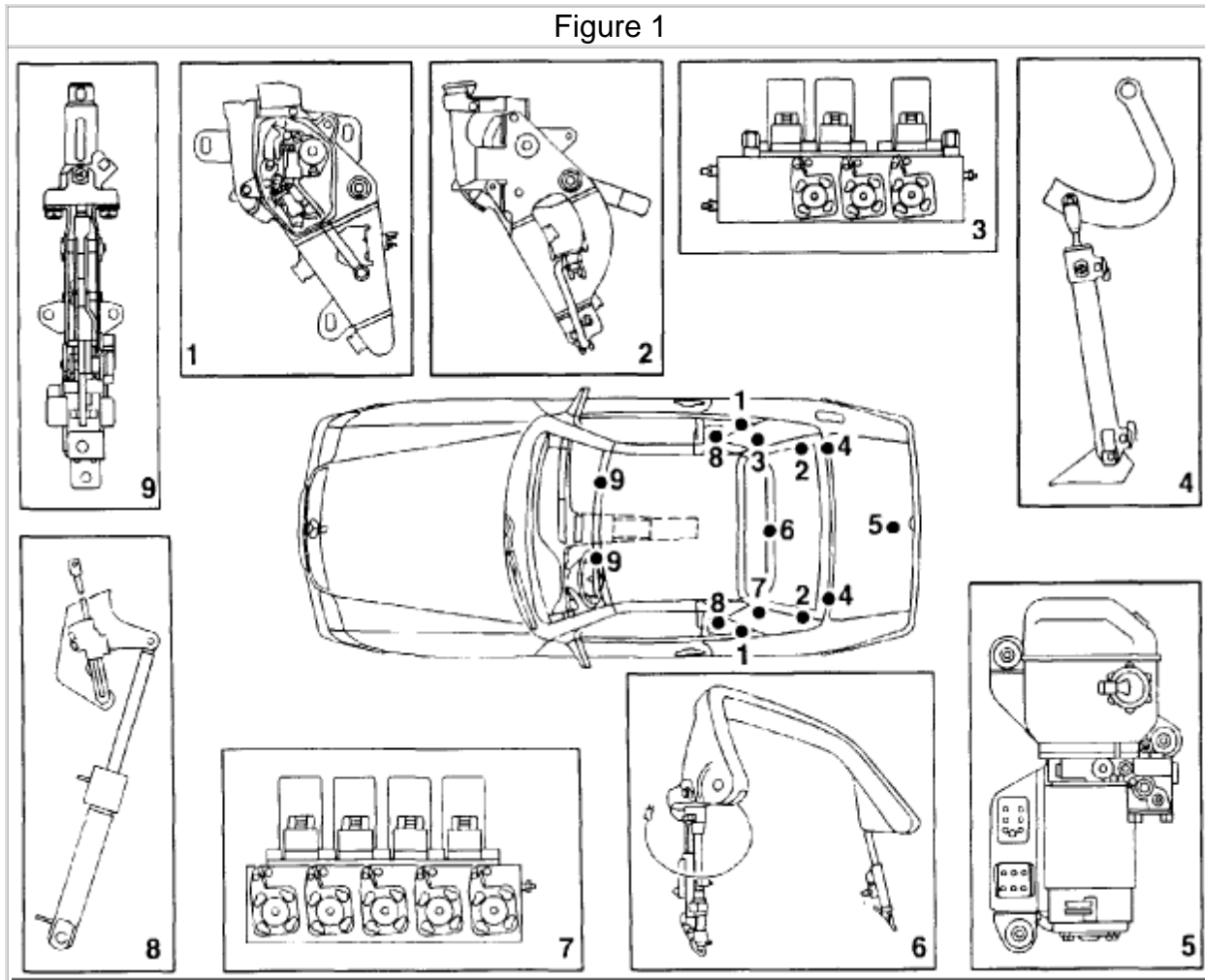

- 1 Center latches
- 2 Rear latches

- 3 Right power soft top valve block (Y55/1) (3 connectors)
- 4 Soft top compartment cover hydraulic cylinder 5RST/RB hydraulic unit
- 6 Roll bar complete
- 7 Left power soft top valve block (Y55/1) (4 connections)
- 8 Soft top and fabric bow hydraulic cylinder
- 9 Front latches

© 2008 ALldata LLC. All rights reserved.

[Terms of Use](#)

[Select Vehicle](#) | [New TSBs](#) | [Technician's Reference](#)

 Component Search:

1998 Mercedes Benz SL 500 (129.067) V8-5.0L (119.982)

[Vehicle Level](#) → [Body and Frame](#) → [Body Control Systems](#) → [Testing and Inspection](#) → [Testing and Inspection Procedures](#) → [Soft Top, Roll Bar \(ST/RB\) \(Manual Deployment\)](#) → [TP - Test Program](#) → [HTP - Hydraulic Test Program](#) → [Preparation For Test](#) ←

Preparation For Test

[Notes](#)

WARNING: Keep clear of the soft top linkage, upper part of the windshield and soft top compartment during soft top locking or unlocking operations (risk of personal injury).

CAUTION : Before beginning the test, check the oil level in the hydraulic unit reservoir and top up if needed.



Conventional Tools, Test Equipment

Graduated beaker (0.5 liter, 10 ml graduations).

Brief description:

In order to make an accurate visual inspection for oil loss from the hydraulic system the windscreen or other personal belongings should be removed from the vehicle.

The hydraulic circuits and components for each soft top operation can be tested separately.

The soft top can be placed in all required positions either by the power soft top switch or (it needed with ignition: **OFF**) by hand.

All of the locks can be locked or unlocked with the soft top wrench.

© 2008 ALLDATA LLC. All rights reserved.

[Terms of Use](#)