

REMOVAL & INSTALLATION

CAUTION: This application is an interference engine. Do not rotate camshaft or crankshaft when timing belt is removed, or engine damage may occur.

TIMING BELT

Removal

1. Disconnect negative battery cable. Remove 2 air ducts mounting bolts from radiator. Loosen fresh air duct clamp at intake housing. Remove hose at resonance chamber. Remove fresh air duct. Remove cooling fan shroud. Remove cooling fan clutch-to-pulley nuts.
2. Remove accessory drive belts. Remove cooling fan and pulley. Remove lower engine splash guard. Remove crankshaft pulley from crankshaft. It is NOT necessary to remove center bolt. Remove upper and lower timing belt covers. See **Fig. 1** .
3. Rotate crankshaft to align camshaft and crankshaft timing marks. See **Fig. 2** and **Fig. 3** . Camshaft "I" and "E" marks should align with marks on rear cover.
4. Loosen tensioner pulley bolt. Pivot tensioner pulley outward to remove tension from timing belt, then retighten tensioner lock bolt. See **Fig. 4** . Mark timing belt rotation direction if old belt is to be reinstalled. Remove timing belt.

1995 Kia Sportage

KIA 2.0L 4-Cylinder - DOHC - 1995-02

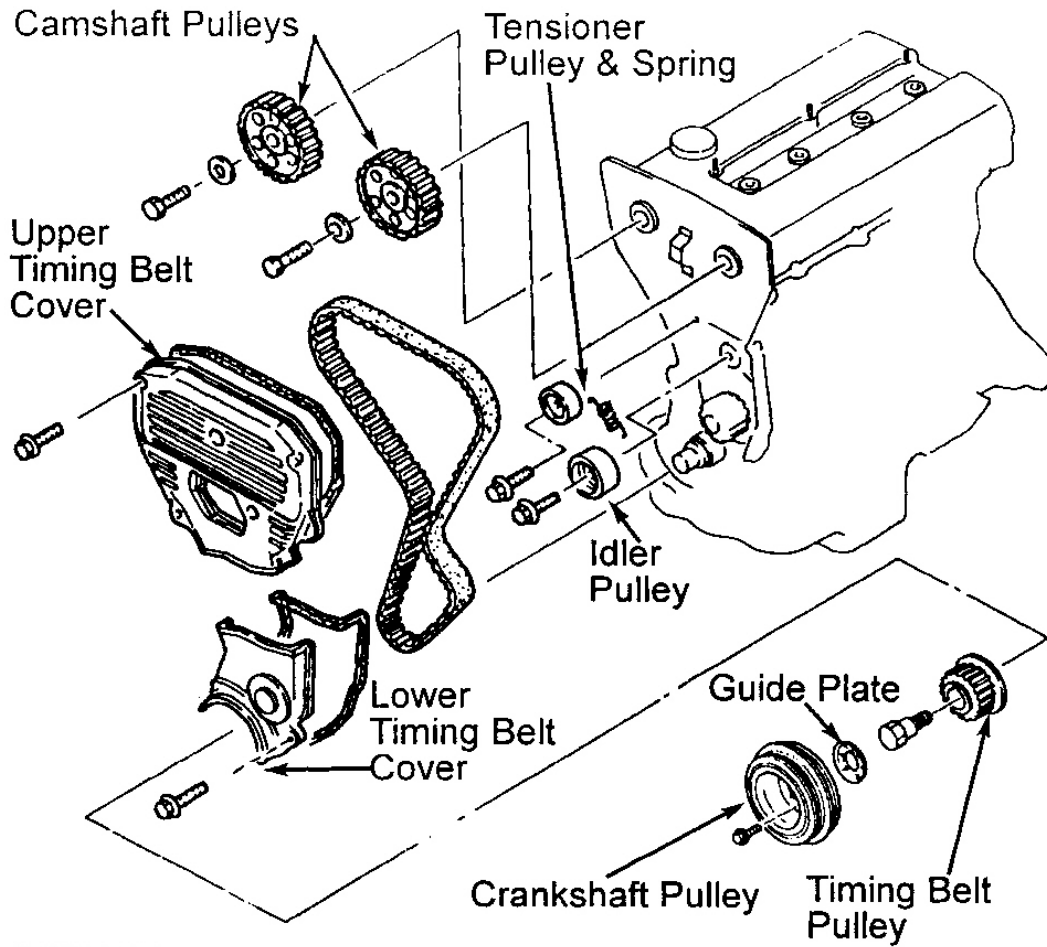

G00214417

Fig. 1: Exploded View Of Timing Belt & Components
Courtesy of KIA MOTORS AMERICA, INC.

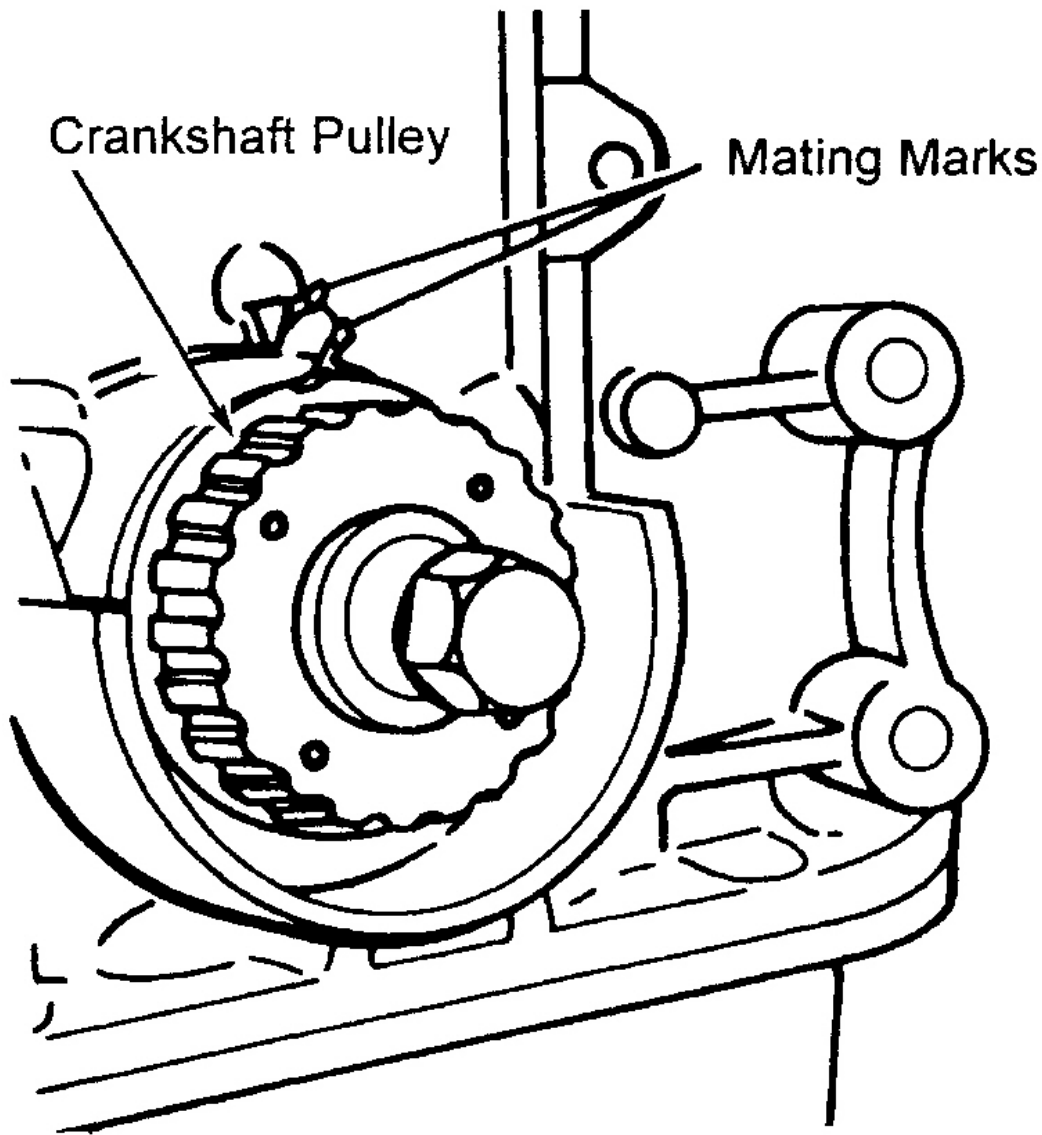

G00214419

Fig. 2: Aligning Crankshaft Pulley Timing Marks

Courtesy of KIA MOTORS AMERICA, INC.

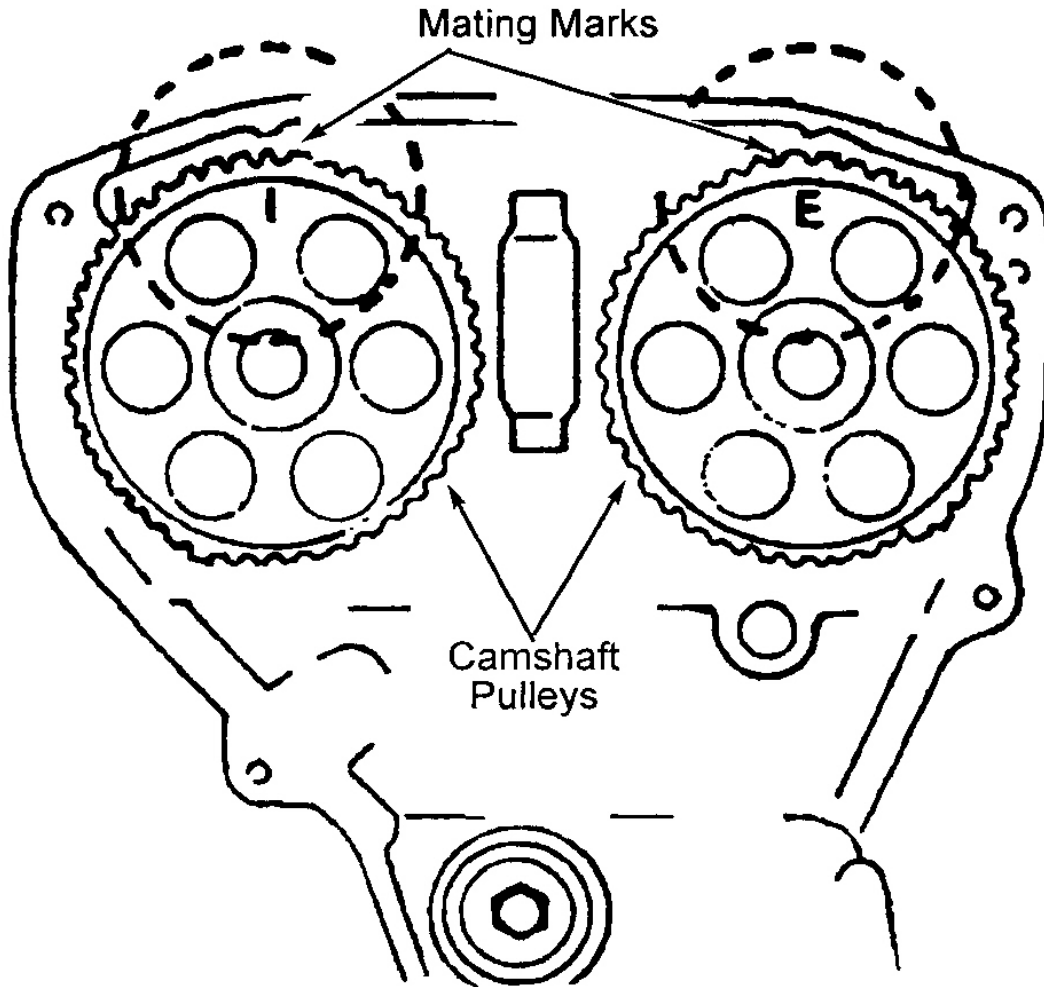

G00214420

Fig. 3: Aligning Camshaft Pulley Mating Marks
Courtesy of KIA MOTORS AMERICA, INC.

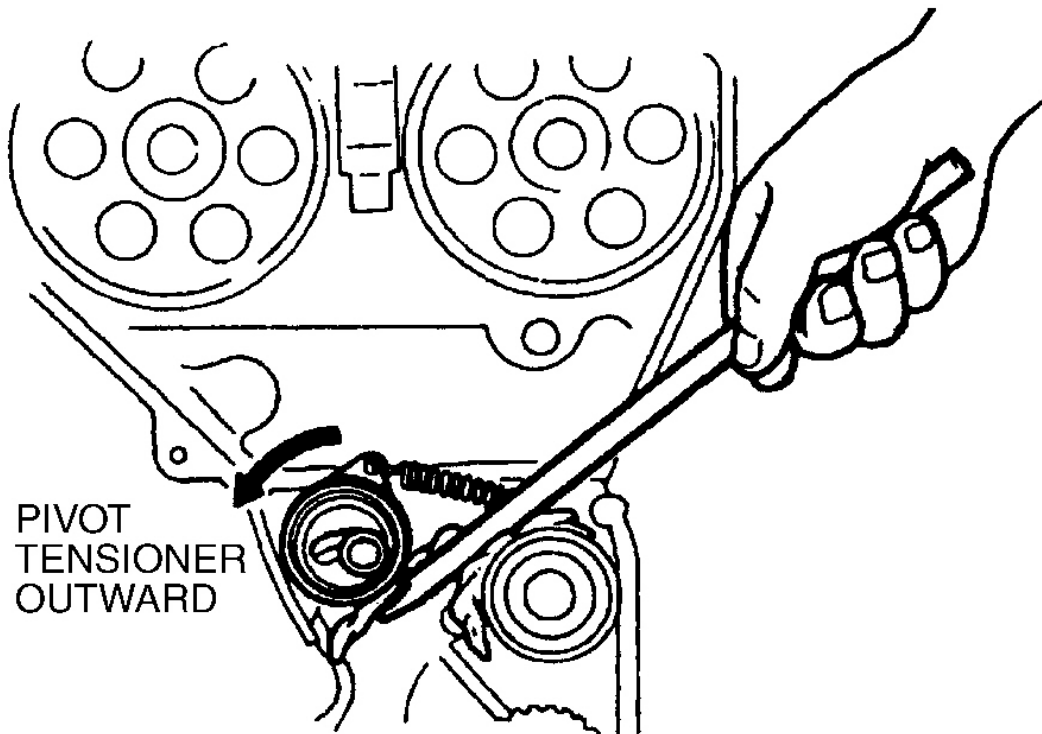

G00214418

Fig. 4: Loosening Tensioner

Courtesy of KIA MOTORS AMERICA, INC.

Installation

1. Ensure crankshaft and camshaft pulleys are still aligned. See **Fig. 3** . Install timing belt so that there is no looseness at tension side, and at camshaft pulleys. If reusing old belt, ensure belt is installed in original direction of rotation. Loosen tensioner pulley bolt.
2. Turn crankshaft 2 revolutions in normal direction of rotation. Check that timing marks are correctly aligned. If timing marks are not correctly aligned, remove belt and realign. After realigning belt, repeat rotation procedure.
3. Turn crankshaft to align "S" mark of exhaust camshaft pulley with rear cover seal plate mating mark. Tighten tensioner pulley bolt.
4. Check that belt deflection is .30-.33" (7.5-8.5 mm) with 22 lbs. (10 kg) of downward pressure on belt, midway between two camshaft pulleys.
5. Install timing belt guide plate with flat side toward belt. Install timing belt covers.
6. To complete installation, reverse removal procedure. Adjust drive belts to proper tension.

TORQUE SPECIFICATIONS

1995 Kia Sportage

KIA 2.0L 4-Cylinder - DOHC - 1995-02

TORQUE SPECIFICATIONS

Application	Ft. Lbs. (N.m)
Camshaft Pulley Center Bolt	35-48 (47-65)
Cooling Fan Clutch-To-Pulley Nuts	24 (32)
Crankshaft Center Bolt	116-123 (157-167)
Crankshaft Pulley-To-Crankshaft Bolts	9-13 (12-17)
Generator Mount Bolts	
Top Generator Bolt	16 (22)
Bottom Generator Bolt	32 (45)
Power Steering Pump Bolts	27-34 (37-46)
Timing Belt Idler Pulley Bolt	27-38 (37-52)
Timing Belt Tensioner Bolt	27-38 (37-52)
Water Pump Bolt	16 (22)
INCH Lbs. (N.m)	
Cooling Fan Shroud Bolts	74 (8)
Fresh Air Duct Mounting Bolts	89 (10)
Timing Belt Cover Bolts	61-87 (7-10)