

POWER STEERING PUMP REPLACEMENT (LS6)

Removal Procedure

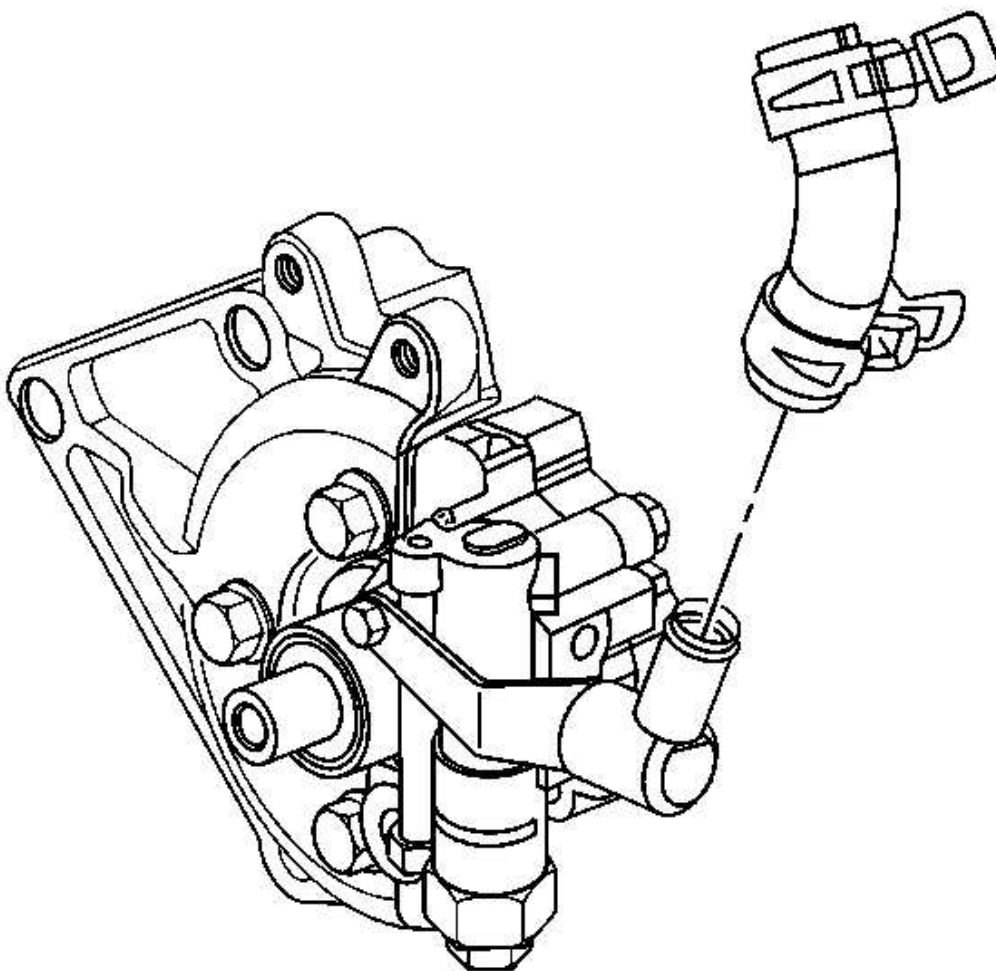

Fig. 28: Identifying Power Steering Reservoir Outlet Hose At Power Steering Pump
Courtesy of GENERAL MOTORS CORP.

1. Remove the front air deflector. Refer to [Air Deflector Replacement - Front](#) in Body Front End.
2. Place a drain pan under the vehicle.
3. Remove the power steering pulley. Refer to [Power Steering Pulley Replacement](#).
4. Remove the power steering reservoir outlet hose from the power steering pump.

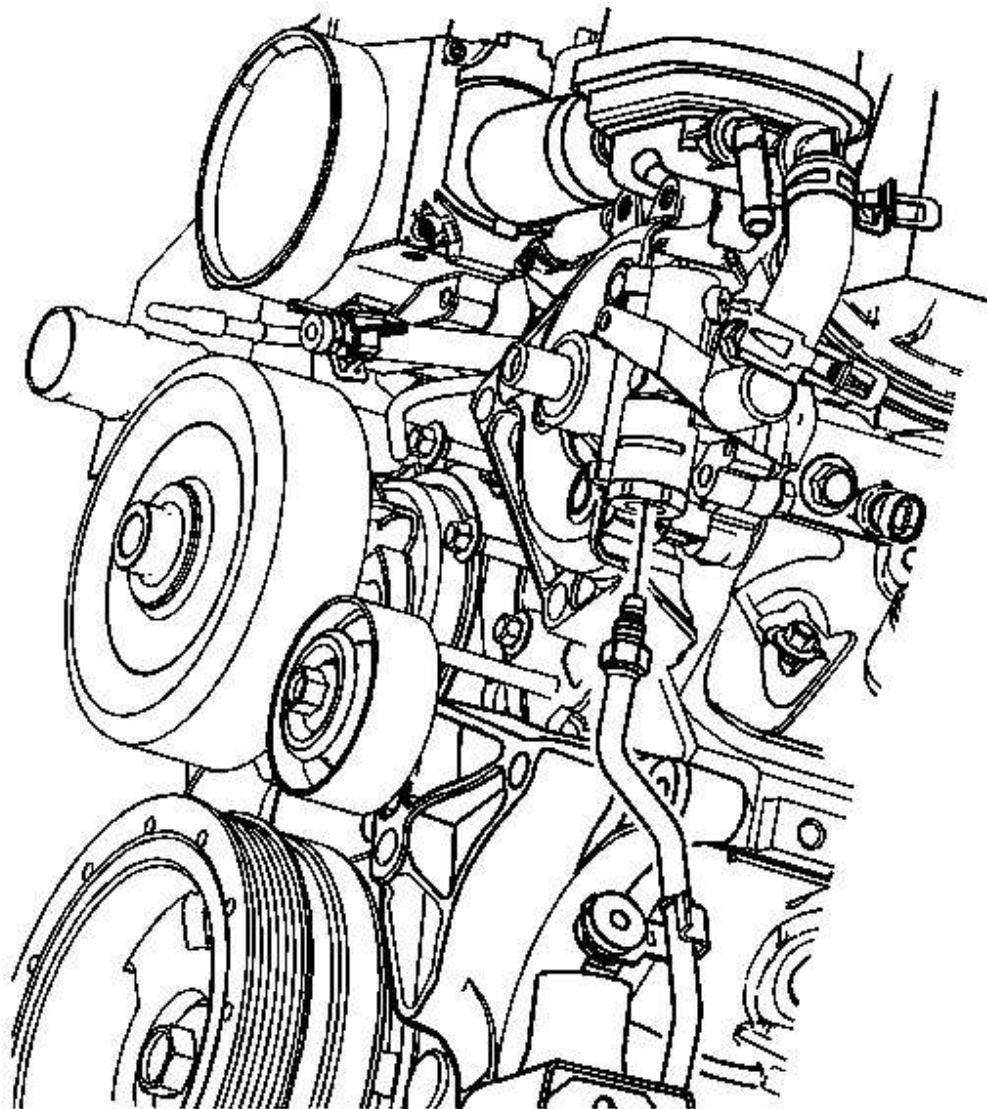

Fig. 29: Identifying Power Steering Pressure Hose At Power Steering Pump
Courtesy of GENERAL MOTORS CORP.

5. Disconnect the power steering pressure line from the power steering pump.

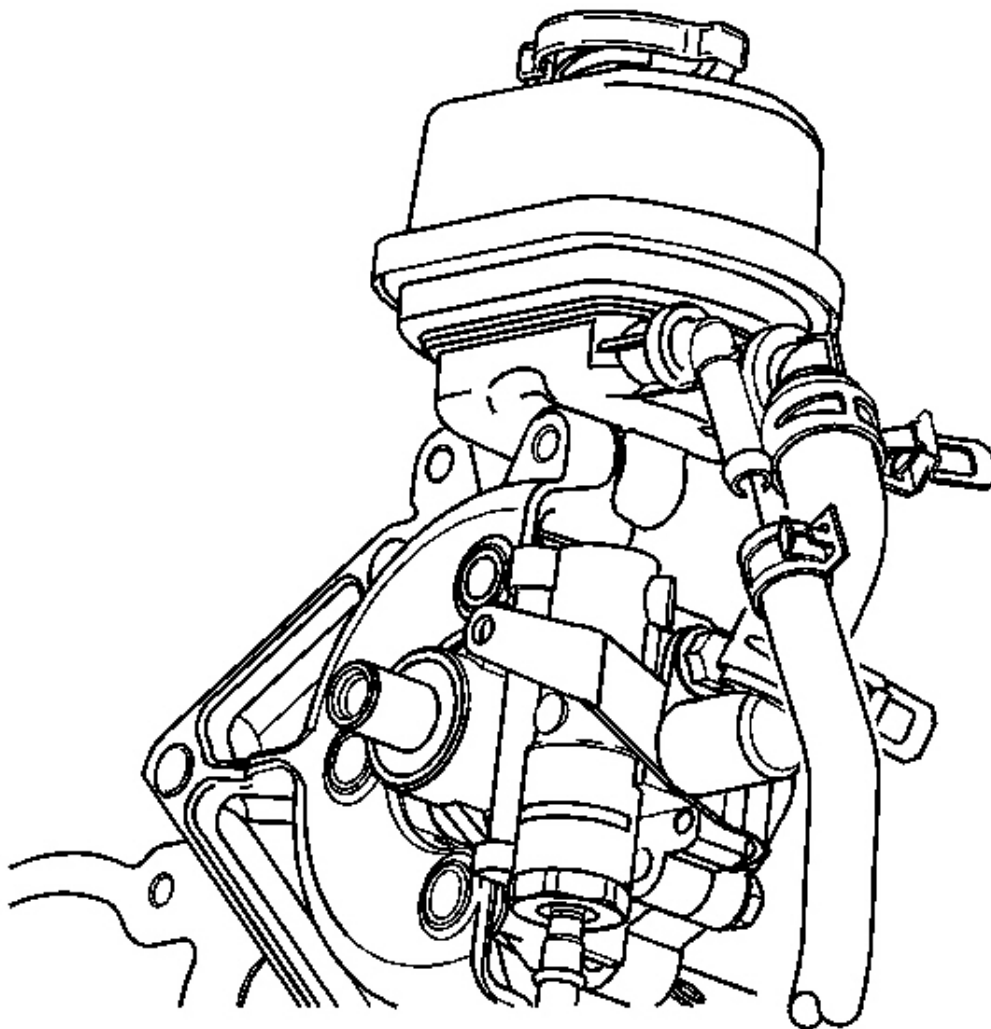

Fig. 30: Identifying Power Steering Cooler Outlet Hose At Power Steering Reservoir
Courtesy of GENERAL MOTORS CORP.

6. Remove the power steering cooler outlet hose from the power steering reservoir

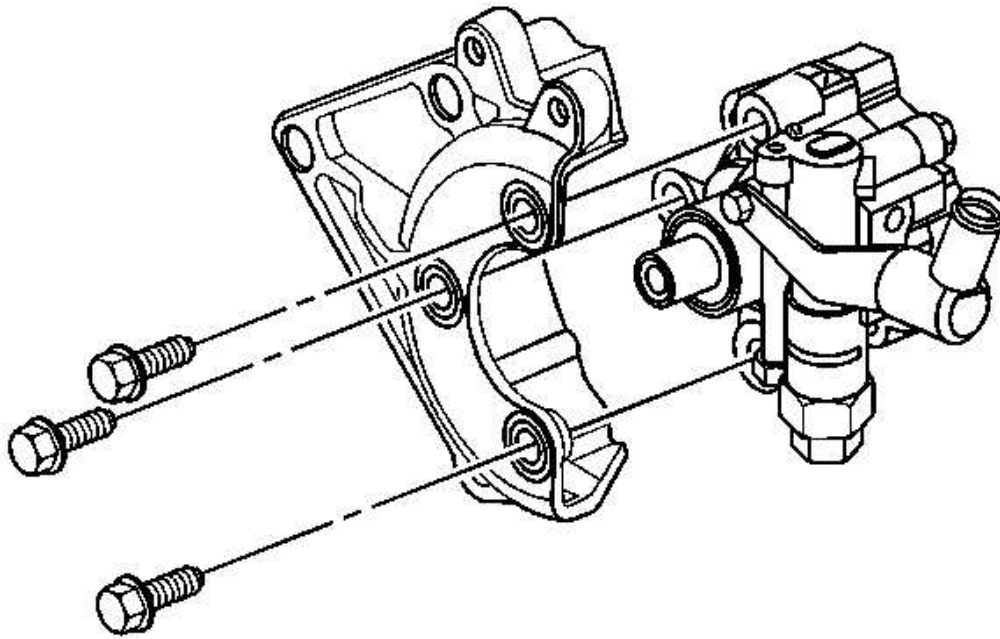

Fig. 31: Removing Power Steering Pump To Power Steering Pump Bracket Bolts
Courtesy of GENERAL MOTORS CORP.

7. Remove the power steering pump to power steering pump bracket bolts
8. Remove the power steering pump from the power steering pump bracket.

Installation Procedure

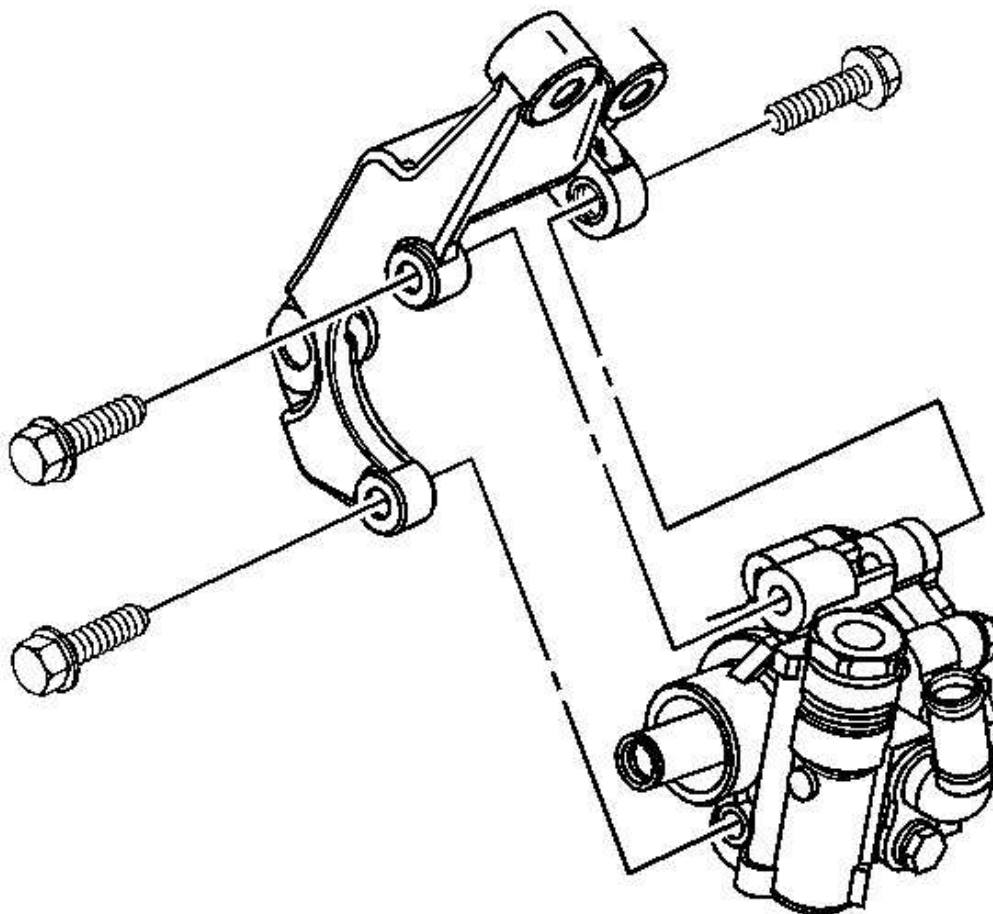

Fig. 32: Removing Power Steering Pump To Bracket Bolts
Courtesy of GENERAL MOTORS CORP.

1. Install the power steering pump to the power steering pump bracket.

NOTE: Refer to **Fastener Notice** in **Cautions and Notices**.

2. Install the power steering pump to power steering pump bracket bolts.

Tighten: Tighten the bolts to 25 N.m (18 lb ft).

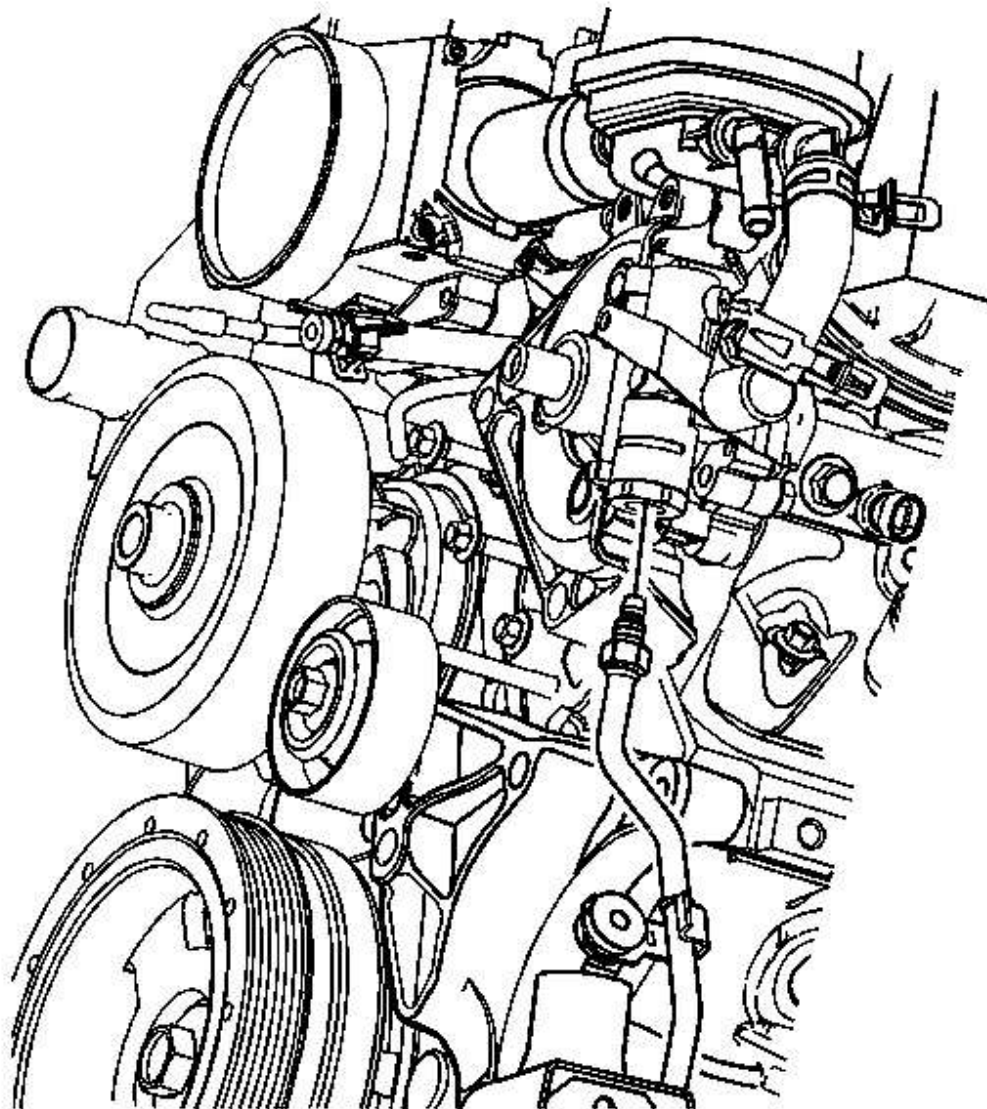

Fig. 33: Identifying Power Steering Pressure Hose At Power Steering Pump

Courtesy of GENERAL MOTORS CORP.

IMPORTANT: Clean the material from the power steering pressure hose and install a new seal.

3. Connect the power steering pressure line to the power steering pump.

Tighten: Tighten the fitting to 40 N.m (30 lb ft).

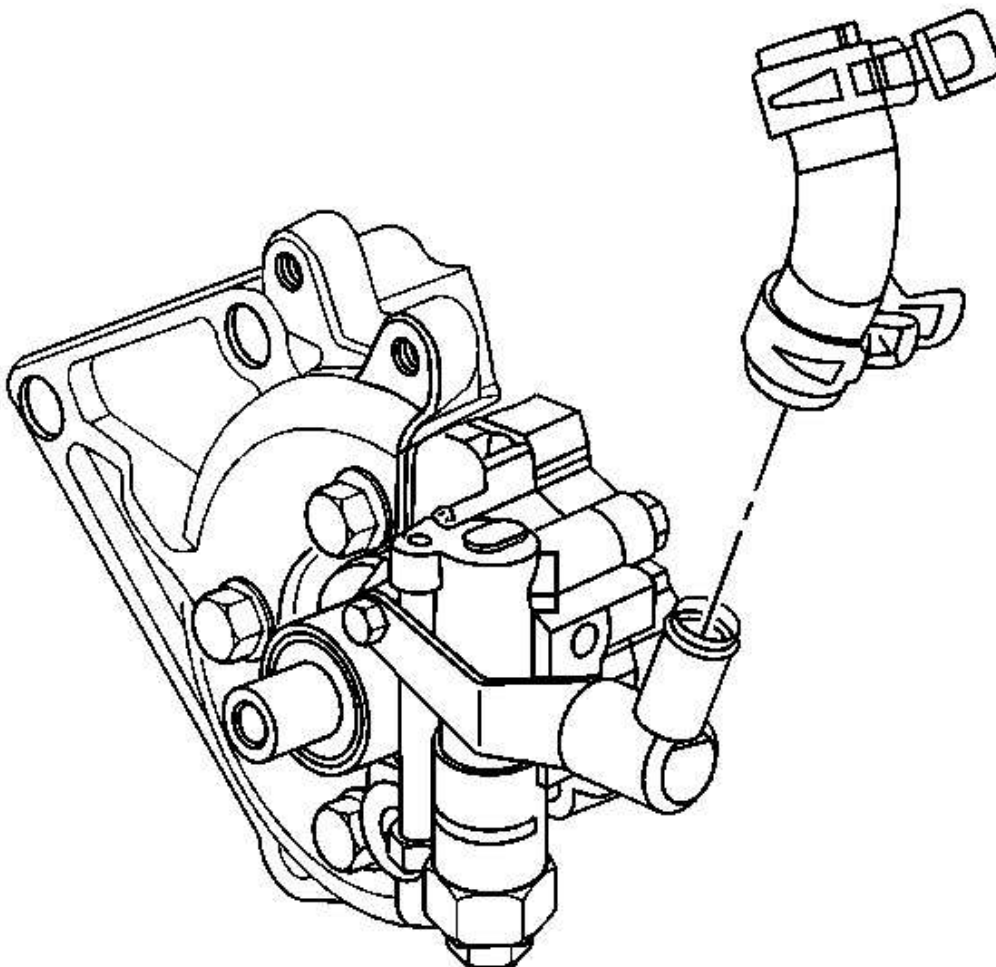

Fig. 34: Identifying Power Steering Reservoir Outlet Hose At Power Steering Pump
Courtesy of GENERAL MOTORS CORP.

4. Install the power steering reservoir outlet hose to the power steering pump.

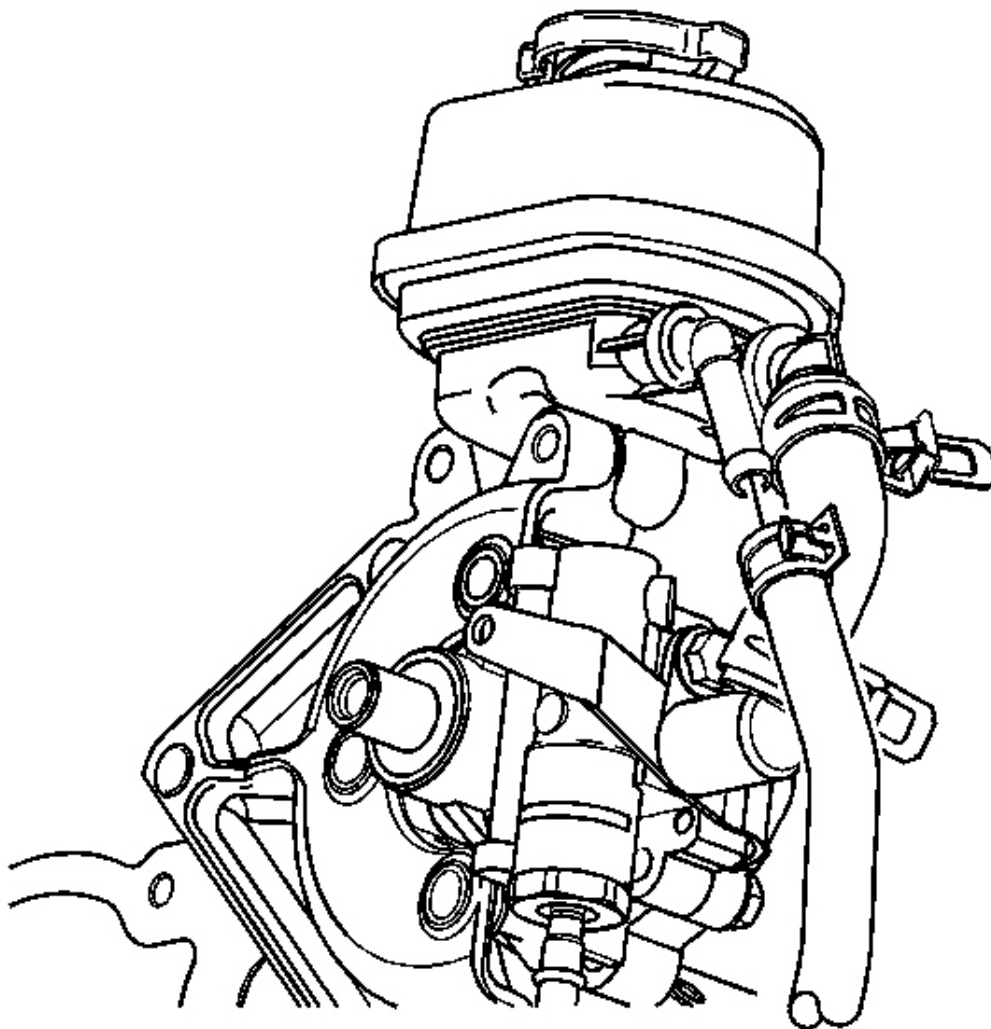

Fig. 35: Identifying Power Steering Cooler Outlet Hose At Power Steering Reservoir
Courtesy of GENERAL MOTORS CORP.

5. Install the power steering cooler outlet hose to the power steering reservoir.
6. Install the power steering pulley. Refer to **Power Steering Pulley Replacement**.
7. Remove the drain pan from under the vehicle.
8. Install the front air deflector. Refer to **Air Deflector Replacement - Front** in Body Front End.