

CD Won't Eject on CR-V

Here's what to do if the CD won't eject from the player on a CR-V:

1. Remove the center panel from the dashboard.
2. Remove the audio unit/CD player from the center panel.
3. Separate the CD player from the audio unit.
4. Inspect the foam spacer on top of the player, and reposition it if needed. The front edge of the spacer should be *exactly 20 mm* from the front edge of the player. If it's too far forward, CDs may not eject.

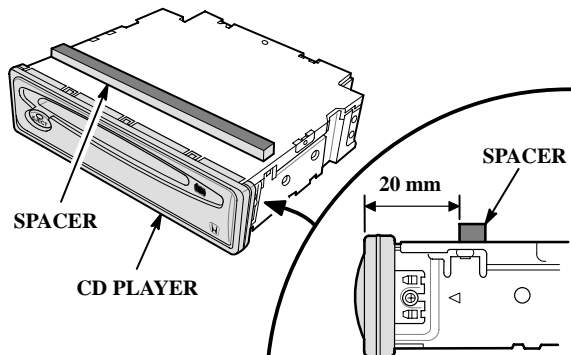

5. Reinstall the audio unit/CD player, and make sure CDs play and eject normally.

Locking the Doors on a '97 Accord SE

You don't have to pull the inside or outside driver's door handle to lock the doors on the '97 Accord SE (the way it's done on other Hondas with power door locks). The driver's door lock interlock feature was eliminated from the SE because the door lock control unit now disables power to the door lock when the key is in the ignition. To lock the doors with the driver's door open or closed, just push the driver's side door lock knob or the door lock switch.

NOTE: Pages 53 and 54 of the '97 Accord SE O/M incorrectly describe the previous style lock.

Head Bolts Are Reusable on Passport V6

As long as the cylinder head bolts on a Passport V6 engine aren't rusted, corroded, or damaged, it's OK to reuse them. The bolts are P/N 8-97011-998-2, H/C 4396446.

Top Tech Contest

In this year's Top Tech Contest we failed to mention that Bill Nelson of Bill Rogers Honda was a Zone winner, as well as one of the National winners from Zone 2. Sorry for the omission, Bill.

Transmitter Programming Reminders for All Hondas

- When you install a security system on any vehicle except a '96-97 Civic LX, you don't need to program the transmitters; they've already been programmed at the factory.
- When you install a security system with keyless entry, the keyless remote transmitters do need to be programmed (except on a '96-97 Civic LX). Programming info is in S/B 96-046, *Keyless Remote Transmitter Information*. For Passport transmitter programming, see the June '97 issue of S/N.
- When you test the operation of a transmitter (security or keyless), make sure the key isn't in the ignition switch. If it is, the transmitter won't work.

Radiator Testing

Here's an easy way to find out if the radiator is causing the engine to overheat. You'll need a pair of wire thermocouples for this test. Thermocouples convert most digital multimeters into pyrometers. They're available from companies like Fluke (800-873-5853).

1. Carefully loosen the radiator cap to relieve system pressure. Use a shop rag, and turn the cap to the first stop, but don't remove it.
2. Loosen the clamp on the lower radiator hose (radiator side), insert a thermocouple wire into the coolant (between the hose and the radiator), and retighten the clamp.
3. Repeat step 2 on the upper radiator hose.
4. With the ends of the thermocouples connected to your pyrometer in the passenger compartment, drive the vehicle under the same conditions as when the overheating occurred.
5. Compare the temperature difference between the two thermocouples:
 - If it's more than 15 degrees F, the radiator is probably OK. Check for other causes of overheating.
 - If it's less than 15 degrees F, replace the radiator.

These readings apply to ambient temperatures of 60 degrees to 80 degrees F. If the air temperature is lower, the difference will be less.

NOTE: A rebuilt radiator may not cool as well as a new one because the fin-to-tube bond is sometimes damaged during the rebuilding process.

MIL Basics

When you diagnose ECM- or PCM-related problems on all models except Passport, the first step is to pay attention to the MIL (malfunction indicator light). The MIL will guide you to the appropriate troubleshooting flowchart in the S/M so you can repair the vehicle. Here are the MIL basics:

When you turn the ignition switch ON (II), the MIL should come on for about two seconds and then go off. If it does, you can then retrieve DTCs with the PGM Tester, and use the appropriate troubleshooting flowchart in the S/M to fix the problem.

If the MIL doesn't come on at all, refer to the first troubleshooting flowchart in section 11 of the S/M for ECM or PCM troubleshooting. A MIL that doesn't come on is usually caused by a blown fuse, a blown bulb, or a poor ground.

If the MIL stays on, or comes on after two seconds, and the engine doesn't start, refer to the second troubleshooting flowchart in section 11 of the S/M for ECM or PCM troubleshooting. A MIL that stays on is usually caused by a blown fuse or a shorted wire.

Civic Rear Dampers Aren't All Bad

If a '96-97 Civic squeaks when going over bumps, don't assume that the rear dampers are bad. This noise can also be caused by loose gusset bolts. Before you replace the dampers, tighten the gusset bolts as described in S/B 96-062, *Squeak From the Rear Seat Area*. To increase the clamping force of the gusset bolts, lubricate the bolts threads with multipurpose grease, and apply silicone sealer to the gussets where they contact the body.

Hood Rattle Fix for Civic

A rattle or clunk from the front of a '96-97 Civic when driving on rough roads may be caused by a misadjusted hood latch. To check the latch, push up and down on the front of the hood. If you hear a "clunk-clunk" sound while doing this, adjust the hood latch as described on page 20-96 of the '96-97 Civic S/M.

Low P/S Fluid on Accord

On '94-97 Accords and '95-97 Odysseys, low power steering fluid without an apparent leak may mean the pinion shaft seal in the steering gearbox is leaking. To verify the leak, check for dampness on the carpet underneath the steering column.

Engine Won't Start? Check Coil & ICM

On models with single-coil ignition systems, if the engine cranks *but there's no spark at the plugs*, check the ignition coil and the ICM (ignition control module [igniter]) by using this procedure:

NOTE: Wire colors for wires referenced here can vary between models, so use the appropriate ETM to ID them.

1. Turn the ignition switch ON (II), and watch the MIL (malfunction indicator lamp).
 - If the MIL doesn't come on, or it comes on and stays on, refer to *MIL Basics* on this page.
 - If the MIL comes on for two seconds and then goes off, go to step 2.
2. Check for battery voltage at the positive wire going to the coil, and at the positive wire going to the ICM.
 - If you have battery voltage, go to step 3.
 - If you don't have battery voltage, check for an open between the ignition switch, the ICM, and the coil.
3. Connect a voltmeter between the coil negative terminal and ground, and record the cranking voltage two ways: first with the wire between the coil and ICM connected, then with it disconnected.
 - If you get about 8 V with the wire connected and 10 V with it disconnected, install a new coil, and retest.
 - If you get about 10 V with the wire connected and disconnected, install a new ICM, and retest.

Are the Wheel Cylinders Really Leaking?

To verify wheel cylinder leakage, pull up the lower edge of the boot on both ends of the wheel cylinder. If any fluid runs out, the cylinder is leaking and must be replaced. If the wetness on the boot is greasy, and no fluid runs out, it's probably just assembly lube; the wheel cylinder doesn't need to be replaced.

S/M Fix: Spark Plug Tightening Torque

On page 23-100 of the '93 Accord S/M, the spark plug tightening torque is listed as 131 lb-ft. Cross this out, and write in the correct torque: 13 lb-ft.

SRS S/M Fix: '94 Civic and Civic del Sol

Here are some corrections needed in the SRS sections of your '94 Civic and del Sol S/Ms.

- *Both S/Ms:* The wire colors for the 2P MES (memory erase signal) connector should be GRY and GRY, not BLK and WHT. To avoid confusion when you erase SRS DTCs with the SCS Service Connector, write in the correct MES wire colors wherever you see the MES mentioned in either of the S/Ms. (It's on several pages in section 23.)
- *Civic S/M:* The DTC chart on page 23-313 has two incorrect "See page" references. For DTCs 5-1 and 10-1, the correct page is 23-350. For DTC 9-1 or No Code, the correct page is 23-334.
- *Civic S/M:* At the bottom of page 23-327 (DTC 2-1 troubleshooting) cross out "To page 23-334," and write in "To page 23-328."
- *Civic S/M:* In the middle of page 23-319 (DTC 1-1 troubleshooting) step 1 of "Check the SRS Unit" should say "Connect the SRS main harness 6P connector to the cable reel."

Trunk Water Leak on '96-97 Accords

To give you a better idea where a trunk water leak is coming from on a '96-97 Accord, look at the condition of the water.

- If the water is dirty, check the damper mount-to wheelhouse seams. If they're leaking, seal them on the tire side with 3M ULTRAPRO sealant, 3M P/N 08302.
- If the water is clear, check the roof moldings, the trunk seal, and the rear glass seals for leakage. Seal leaks in these areas with 3M Clear Auto Sealer, 3M P/N 08551.

ATTS Function Test Tips

When you do an ATTS Function Test on a '97 Prelude (S/B 97-023), use these tips to save yourself some time:

- The test begins when you turn the ignition switch on, and lasts for 20 seconds. If you don't complete the test within 20 seconds, start over.
- Before you start the engine (step 5) shift the trans into reverse.
- In step 6, start off in 2nd gear, not first; you'll get to the 12 mph test speed faster.

NOTE: You can also do an ATTS function test with the PGM Tester (SN 723 software or later).

ATR Program Has a New Phone Number

The ATR (Automatic Transmission Remanufacturing) program telephone number has changed. The new number is (937) 332-6152. Call this number to order a remanufactured A/T, for A/T availability, and for general questions on the program. For technical questions, call Tech Line.

See the November '95 issue of S/N for more info on the program.

Replacement ATF Filters

Replacement ATF in-line filters (the kind you get with a remanufactured A/T) are available separately for all models except Passport. Here's the model and part number info:

Model	P/N	H/C
'86-89 Accord, '88-91 Prelude	25420-PF4-315	3828449
'88-91 Civic	25420-PL4-305	3828456
'90-93 Accord (large filter)	25420-PX4-A00	3828498
'90-97 Accord, '92-97 Civic, '92-97 Prelude, '95-97 Odyssey, '97-98 CR-V (small filter)	25420-P24-A01	3959574

Remanufactured P/S Racks

Remanufactured power steering rack and pinion assemblies are now available for '86-97 Accords and '96-97 Civics. These racks come complete with inner tie-rods, boots, and boot clamps. They're backed by the Honda replacement parts limited warranty for 12 months or 12,000 miles. Here's the model and part number info:

Model	P/N	H/C
'86-89 Accord	53601-SE0-A59RM	4719845
'90-93 Accord	53601-SM4-A05RM	4720850
'94-97 Accord	53601-SV4-A02RM	5335815
'95-97 Accord V6	53601-SV7-A01RM	5335831
'96-97 Civic	53601-S04-A51RM	5276902

The Basics of RFG and Oxygenated Fuel



You've probably been hearing a lot about RFG (reformulated gasoline) and oxygenated fuel, but how much do you know about them? For instance, all RFGs contain an oxygenate, but did you know that not all oxygenated fuel is RFG. Actually, there are many differences between these fuels and conventional fuels. Here's the latest info.

What's RFG?

Although RFG and conventional fuel share most of their chemical components, RFG has less benzene (a known cancer causing agent), and it contains an oxygenate (more about oxygenates later). In its summer grade, RFG is less volatile than conventional fuel. (Volatility is a measure of the fuel's tendency to turn from liquid to vapor.) Lower volatility means that engines running on RFG aren't as prone to vapor lock and hot restart problems.

Use of RFG was first proposed to Congress by the Environmental Protection Agency (EPA) in the Clean Air Act of 1990. By '95, use of RFG was required in several metropolitan areas where smog is a major problem. RFG will soon be required in many other regions too. In '98, stricter fuel regulations will further improve RFG by

- reducing volatility for better control of vapor lock and prevention of hot restart problems,
- lowering the sulfur content to make catalytic converters more effective, and
- reducing olefins to cut down on fuel system deposits.

What's Oxygenated Fuel?

Oxygenated fuel is a conventional gasoline with a chemical oxygenate added to it. The oxygenate can be an alcohol or an ether. The most commonly used alcohol is *ethanol*. The most commonly used ether is *MTBE* (methyl tertiary butyl ether).

Ethanol is made by fermenting corn or grain. It was first used as an octane enhancer in the '70s. Back then, fuel blended with ethanol was called "gasohol." To oxygenate the fuel, a 10 percent dose of ethanol is added. Today, ethanol is used in about 10 percent of all gasoline sold in the U.S.

MTBE is created from a chemical reaction between isobutylene and methanol. Like ethanol, MTBE was originally used as an octane enhancer. To make oxygenated fuel, a 15 percent dose of MTBE is added. MTBE vapor has a distinct ether smell which many people find unpleasant. But even though it

smells bad, MTBE vapor is considered less of a health risk than fuel vapors like benzene.

Recently, MTBE has become a hot debate item; it's been linked to contamination of ground water supplies in some areas of the country. Further government research is still needed before we know if MTBE will continue to be used as an oxygenate.

Whether it's made with ethanol, MTBE, or another alcohol or ether, the primary function of oxygenated fuel is to increase fuel octane, provide more complete combustion, and reduce CO (carbon monoxide) emissions. For CO reduction, oxygenated fuel is sold in many parts of the country during the winter months.

On pumps that dispense oxygenated fuel, you'll see a sticker with this info:

THE GASOLINE DISPENSED FROM THIS PUMP IS OXYGENATED AND WILL REDUCE CARBON MONOXIDE POLLUTION FROM MOTOR VEHICLES. THE REQUIRED REGULATORY COMPLIANCE PERIOD IS: NOVEMBER 1 THROUGH FEBRUARY 29.

Usage, Cost, and Benefits

Year-round, RFG makes up about 30 percent of the gasoline sold in the country. And in 30 metropolitan areas where RFG isn't required, oxygenated fuel is the only fuel sold during winter months. Both fuels add about 10 cents to the cost of each gallon of gasoline.

RFG and oxygenated fuels produce about 20 percent less air pollution than conventional fuels because they burn cleaner and evaporate slower. *Using these new fuels eliminates over two billion pounds of air pollutants per year. This is the equivalent of removing 8 million cars from the road.*

Use of RFG and oxygenated fuel will continue to rise. By the year 2000, they'll make up most of the fuel sold in the U.S.

HONDA ServiceNews

©1997 American Honda Motor Co., Inc. - All Rights Reserved. Published by AHM Service Publications, 1919 Torrance Blvd., Torrance, CA 90501-2746. All suggestions become the property of American Honda Motor Co., Inc.; sending a suggestion gives American Honda permission to publish it without further consideration.



WE SUPPORT
VOLUNTARY TECHNICIAN
CERTIFICATION THROUGH
National Institute for
AUTOMOTIVE
SERVICE
EXCELLENCE

ASN 18977 (9707)