

Assembly

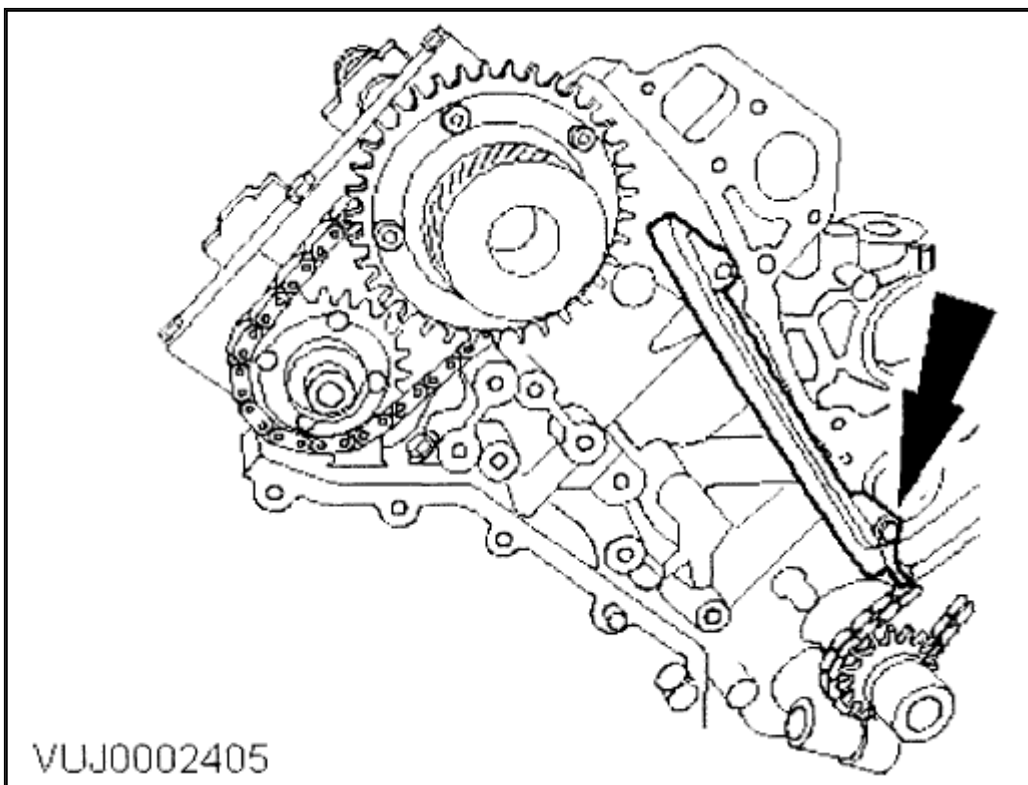

Zoom

Sized for Print

50. Install the [timing chain guide](#). Tighten to **12 Nm** .

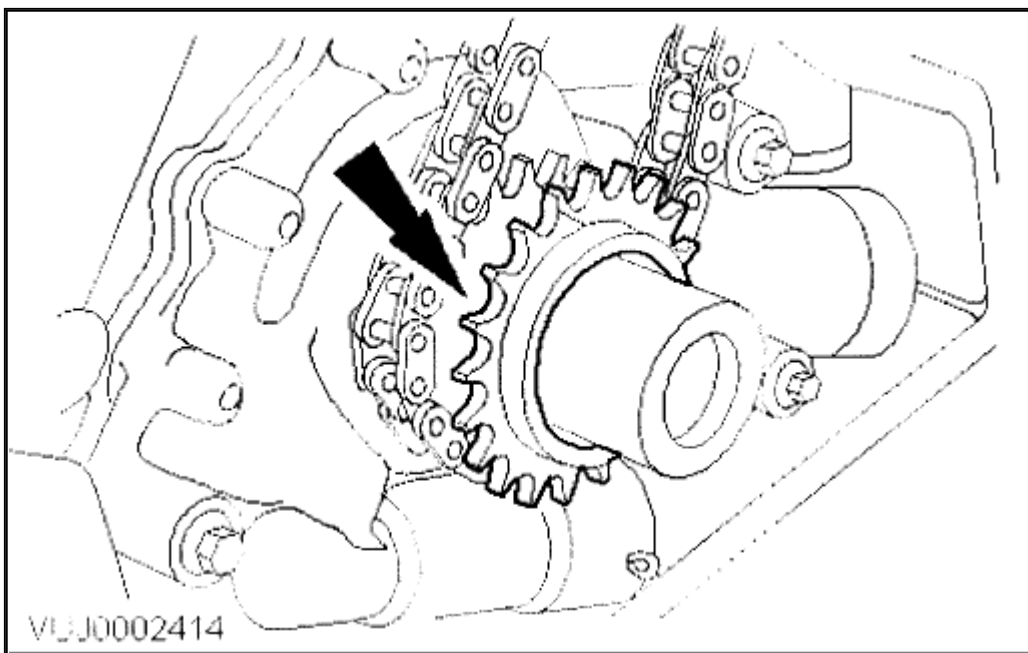

Zoom

Sized for Print

51. Install the crankshaft sprocket.

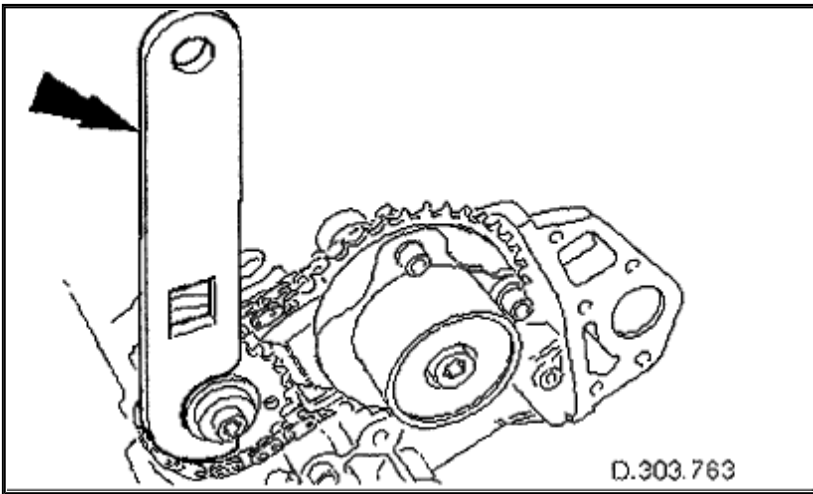

Zoom

Sized for Print

52. Install the chain tensioning tool 303-532 to the exhaust camshaft sprocket. Reposition the sprocket (and the VVT unit) for the most advantageous position for use of the tool. Remove the tool.

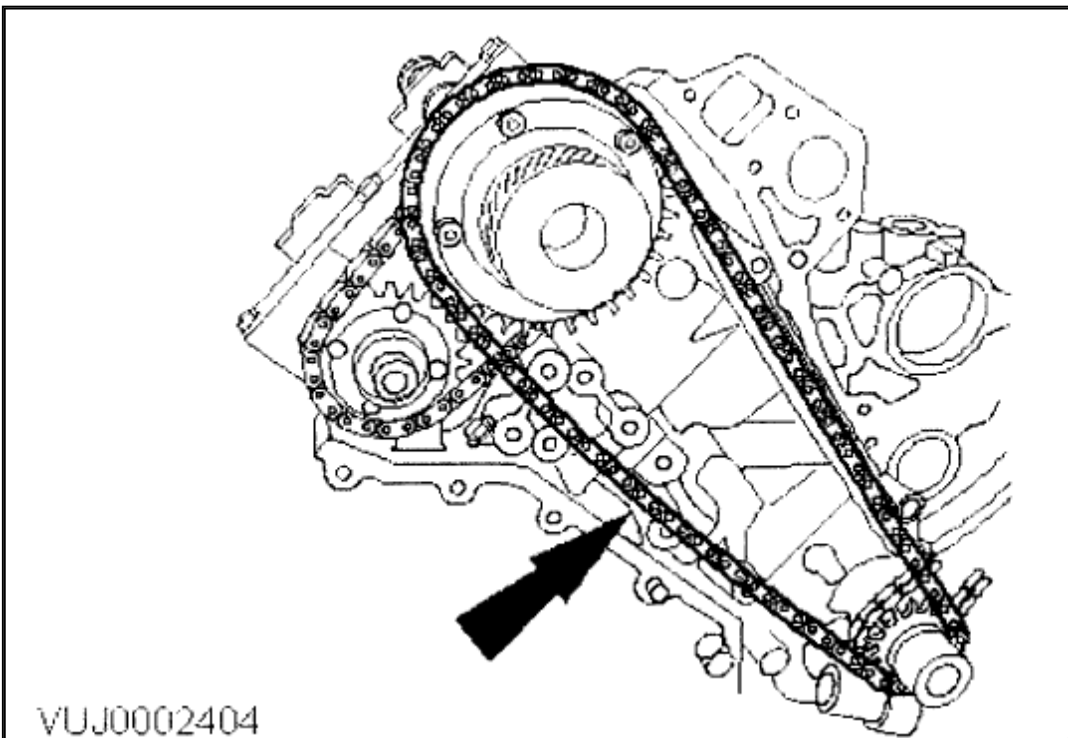

Zoom

Sized for Print

53. Install the primary [timing chain](#). Install the primary chain over the crankshaft sprocket and the WT unit sprocket. There must be no slack on the drive side of the primary chain and the WT unit must not be rotated on the [camshaft](#).

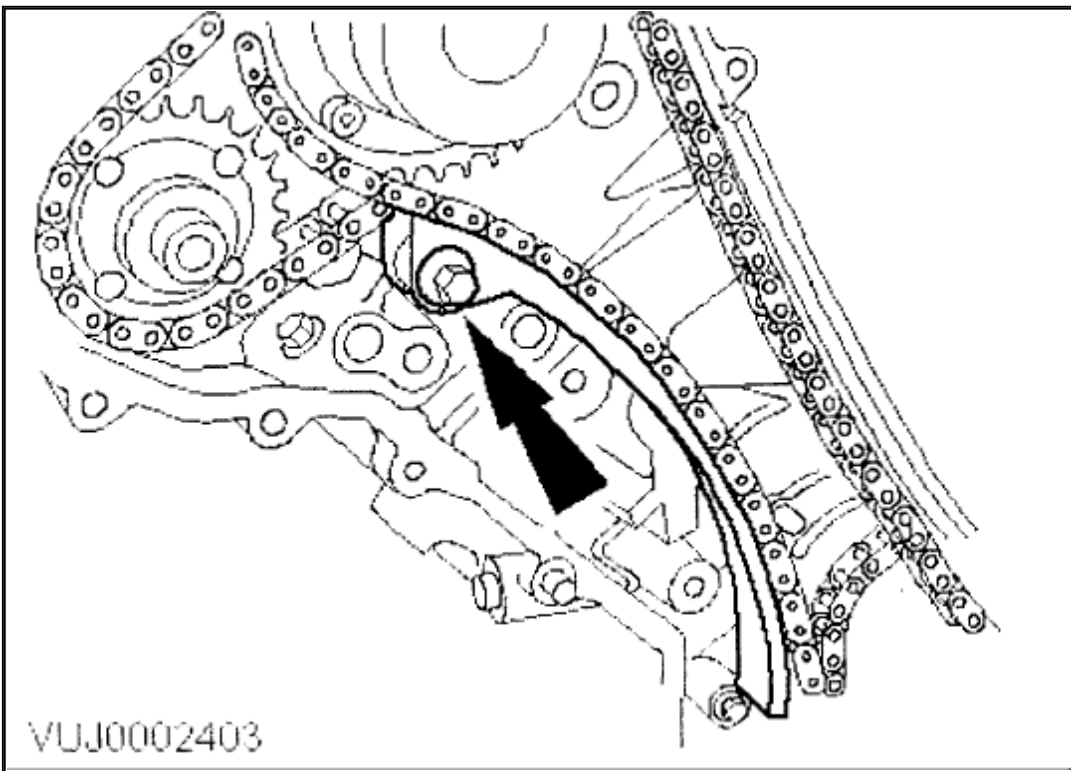
[Zoom](#)[Sized for Print](#)

54. Install the [timing chain tensioner](#) blade. Tighten to **14 Nm** .

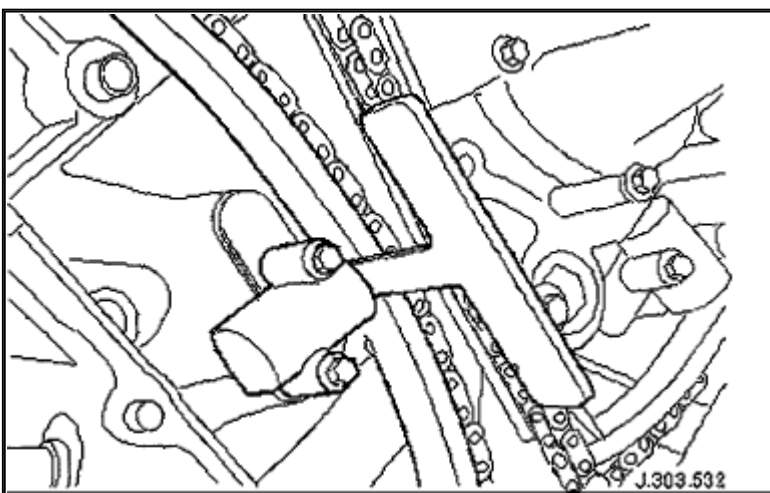
[Zoom](#)[Sized for Print](#)

55. Install the primary chain tensioner assembly. Use a wedge 303-533 (or two if

required) between the primary chain tensioner and tensioner blade, to take up the slack in the chain. Tighten to **12 Nm**.

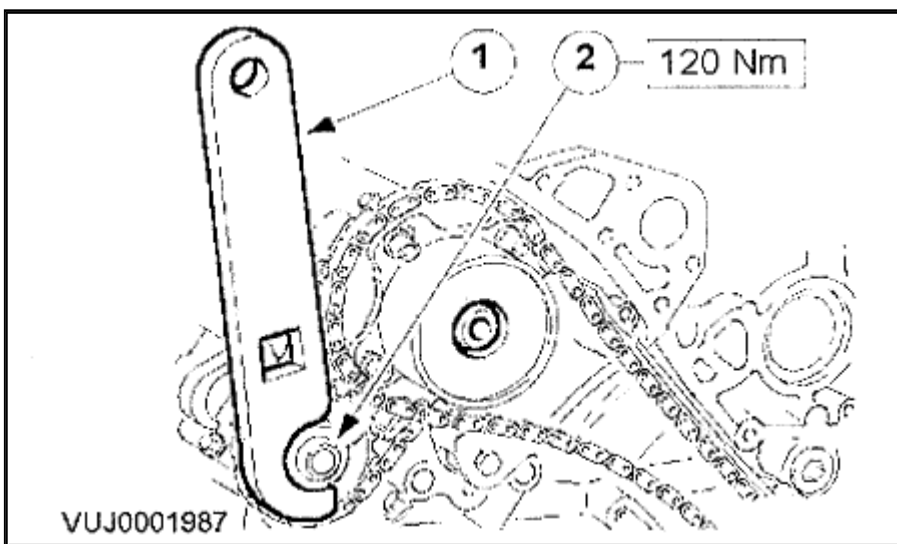

Zoom

Sized for Print

56. Tighten the exhaust camshaft sprocket securing bolt. Install the chain tensioner tool 303-532 to the sprocket holes.

- Apply force to the tool in an anti-clockwise direction to tension the chain on its drive side.

While applying the opposing force to sprocket and chain, tighten the sprocket bolt.

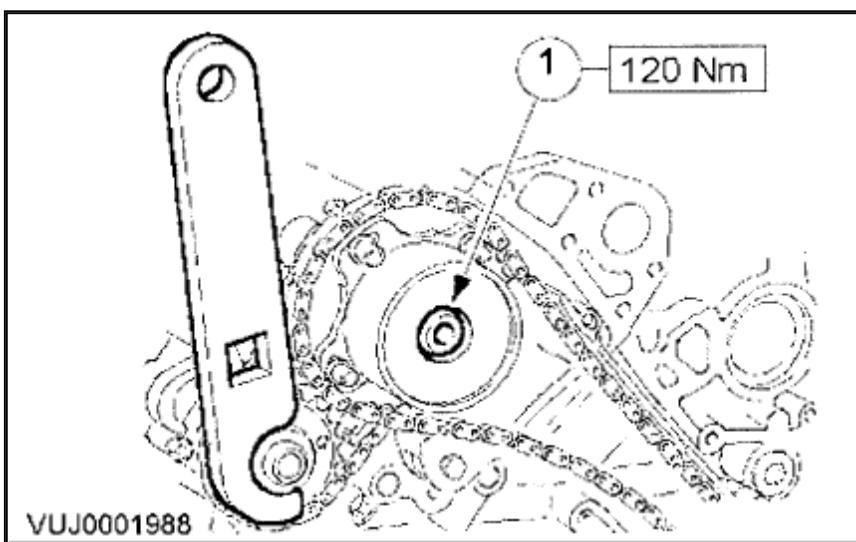

Zoom

Sized for Print

57. Tighten the VVT unit bolt. While still applying the opposing force to the sprocket and

chain (using 303-532), check that the wedges are still in place, tighten the VVT unit bolt. Remove the chain tensioning tool and the wedge(s).

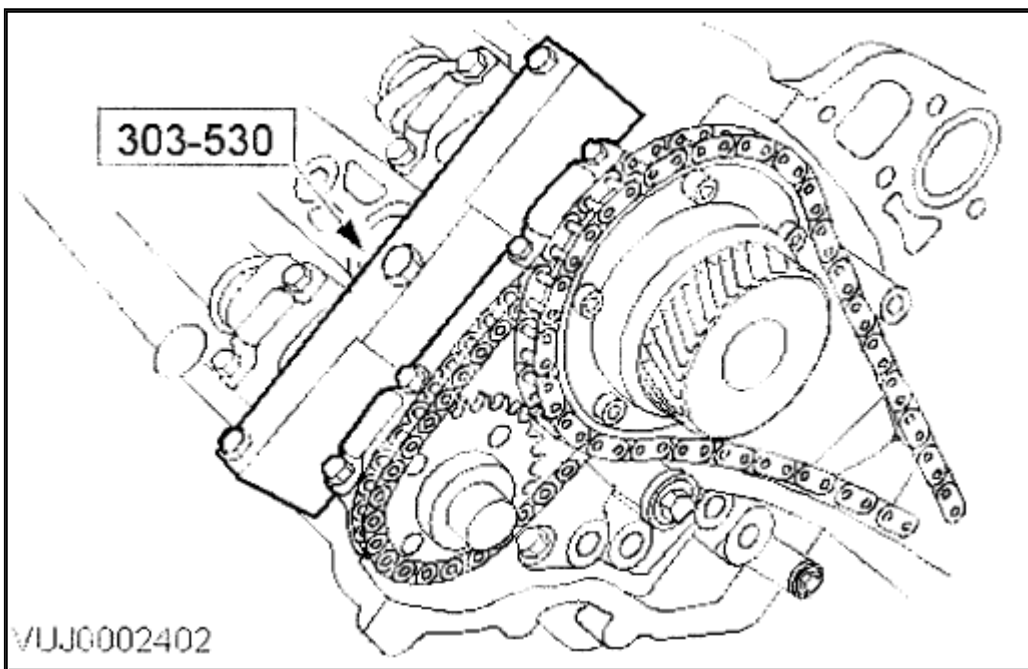

Zoom

Sized for Print

58. Remove the [camshaft](#) setting tool.

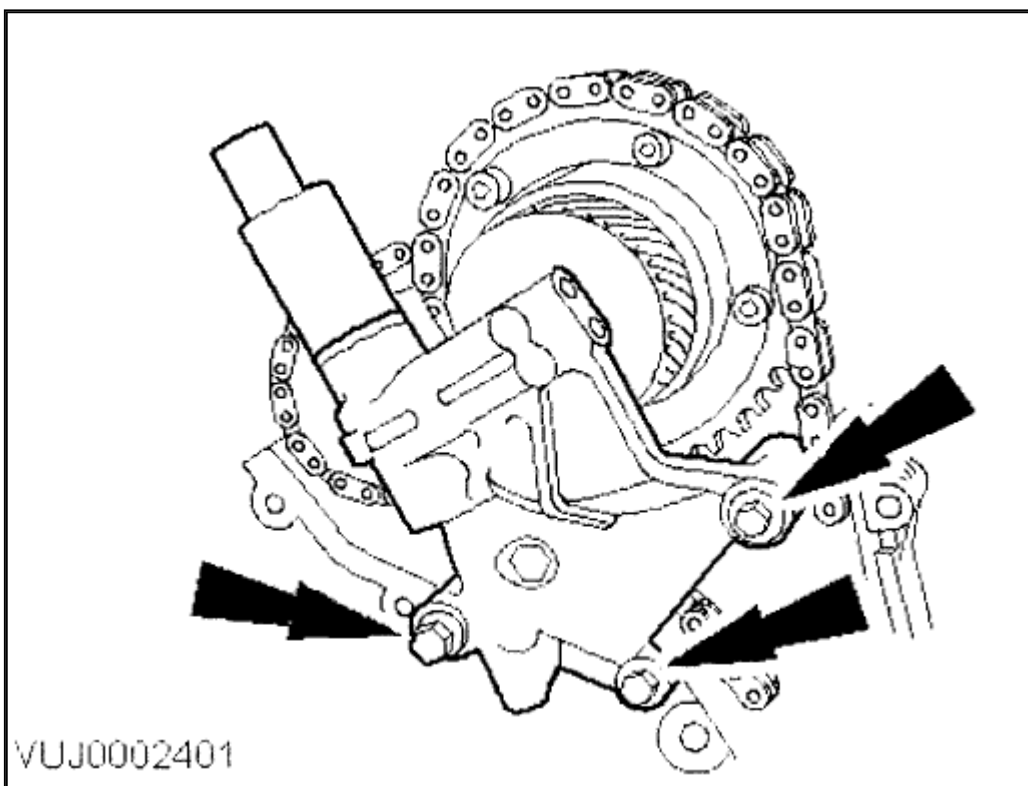

[Zoom](#)[Sized for Print](#)

59. Install the right-hand Variable Valve Timing (**VVT**) solenoid and bush carrier assembly. Install new 'O' ring seals. Tighten to **21 Nm** .

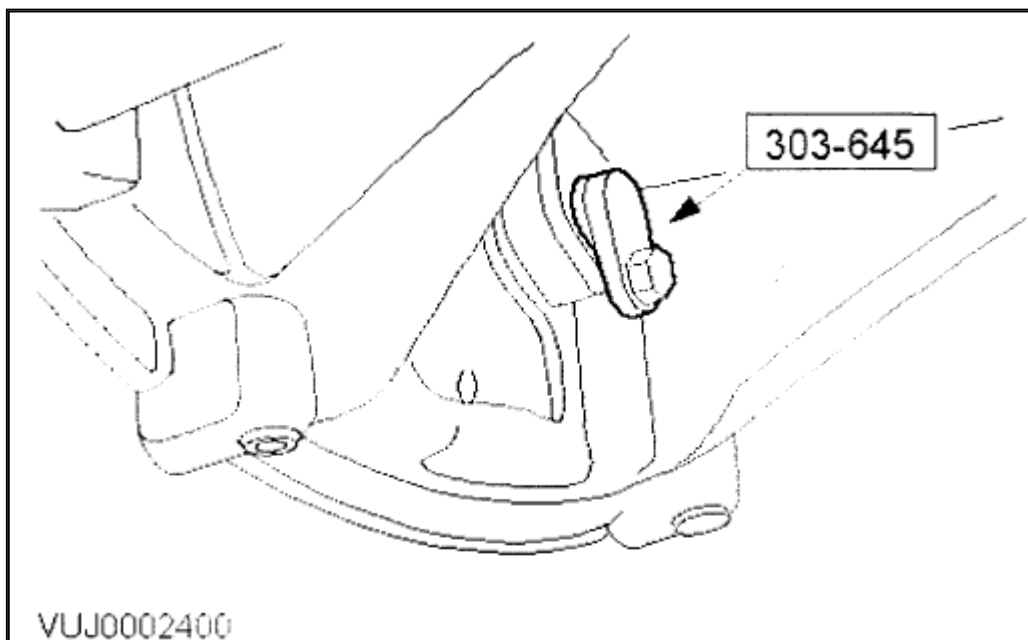
[Zoom](#)[Sized for Print](#)

60. Remove the [crankshaft](#) setting peg 303-645 from the crankshaft position sensor location.
61. Carry out a [valve clearance](#) check. For additional information, refer to[Valve Clearance Check]

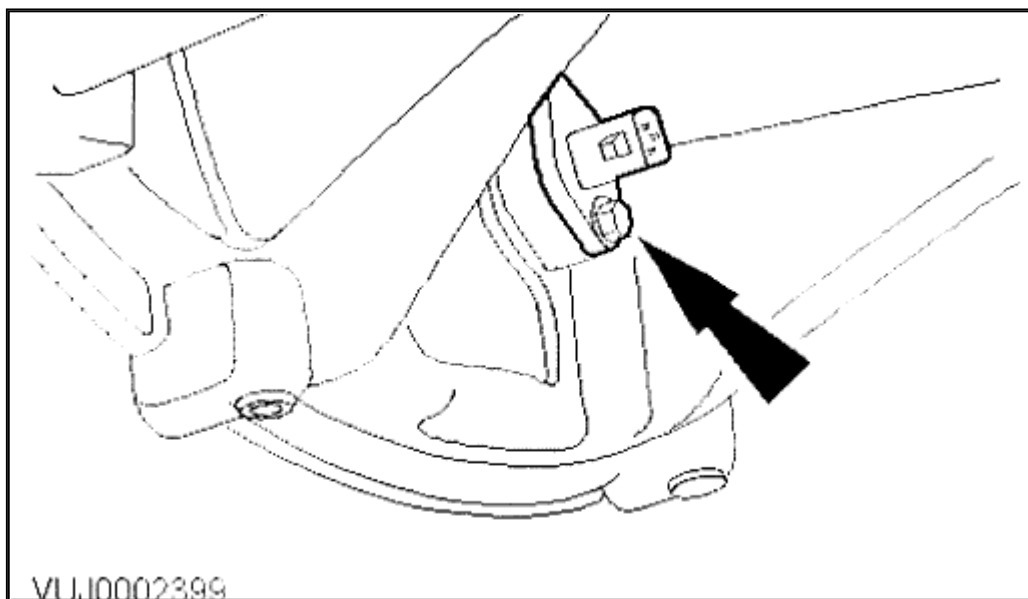

[Zoom](#)[Sized for Print](#)

62. Install the [Crankshaft](#) Position (CKP) sensor. Tighten to **7 Nm** .

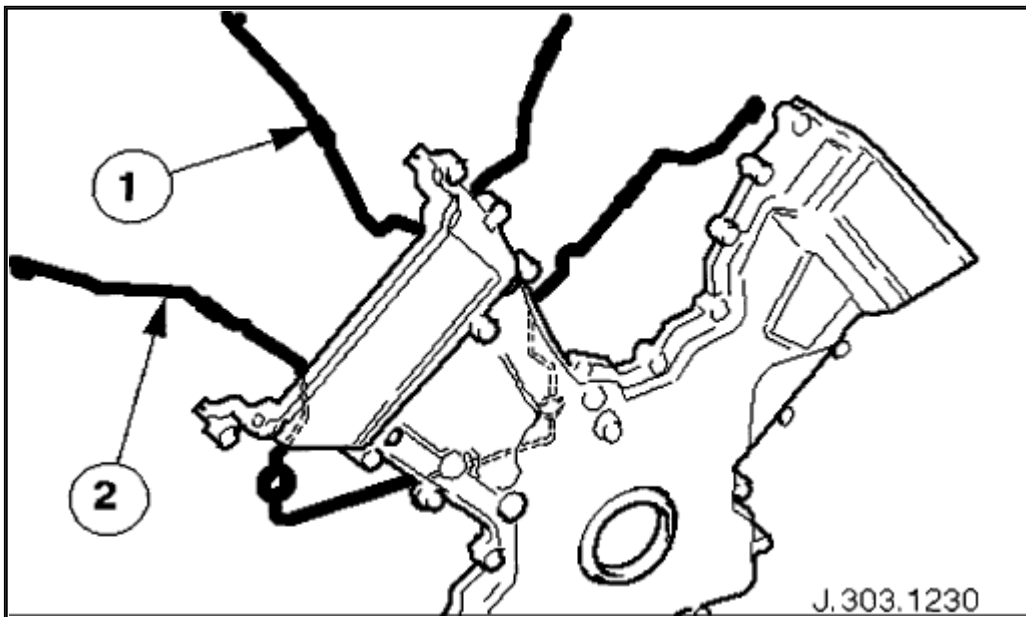
[Zoom](#)[Sized for Print](#)

63. Install new seals to the [timing cover](#). Install the new seal to the inner groove on the face of the timing cover. Install the new seal to the outer groove on the face of the [timing cover](#). Remove the transit ring and check that the oil seal is not damaged. Install and fully locate, a new seal for the [idler pulley](#).

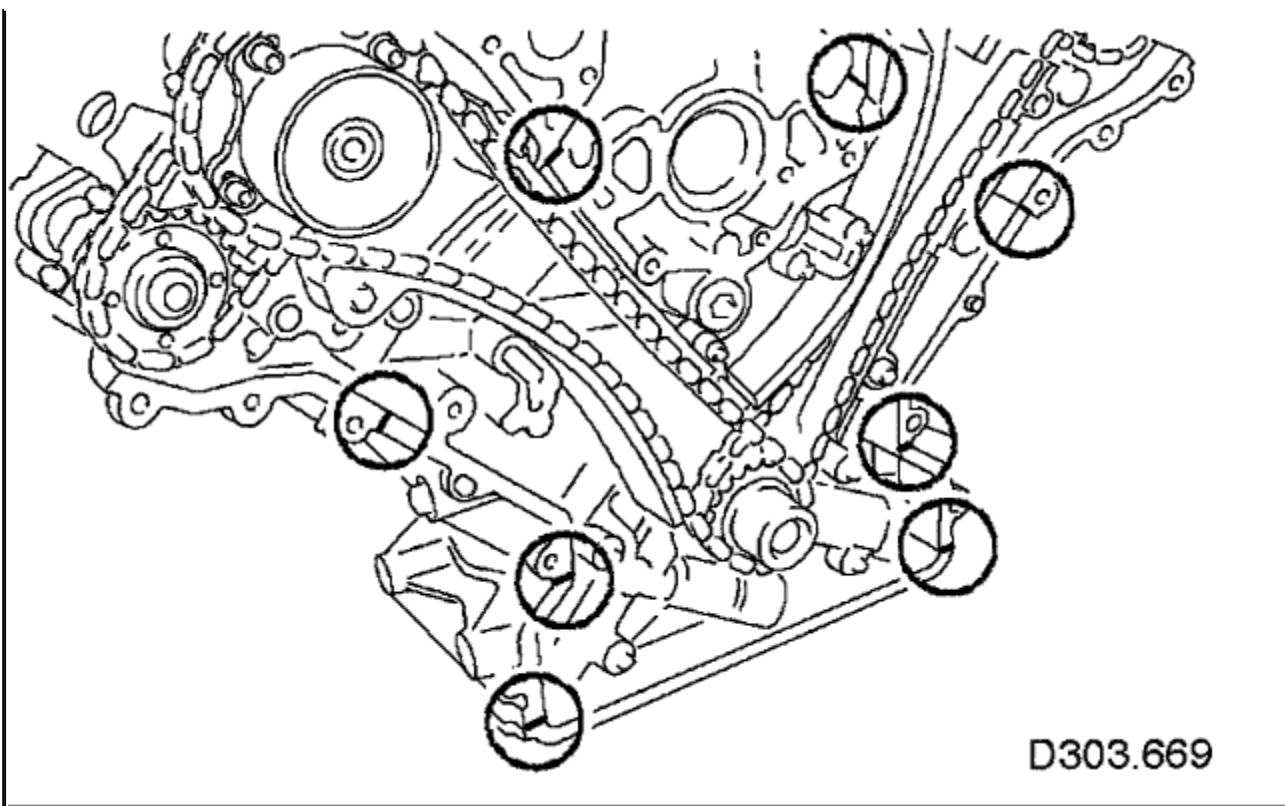

Zoom

Sized for Print

64. Apply sealant to the eight joints on the engine face. Sealant beads to be **3 mm** diameter and **12 mm** long. Cut the nozzle of the sealant tube to produce a **3 mm (0.12 inch)** bead. Install and tighten the securing bolts within twenty minutes of sealant application).

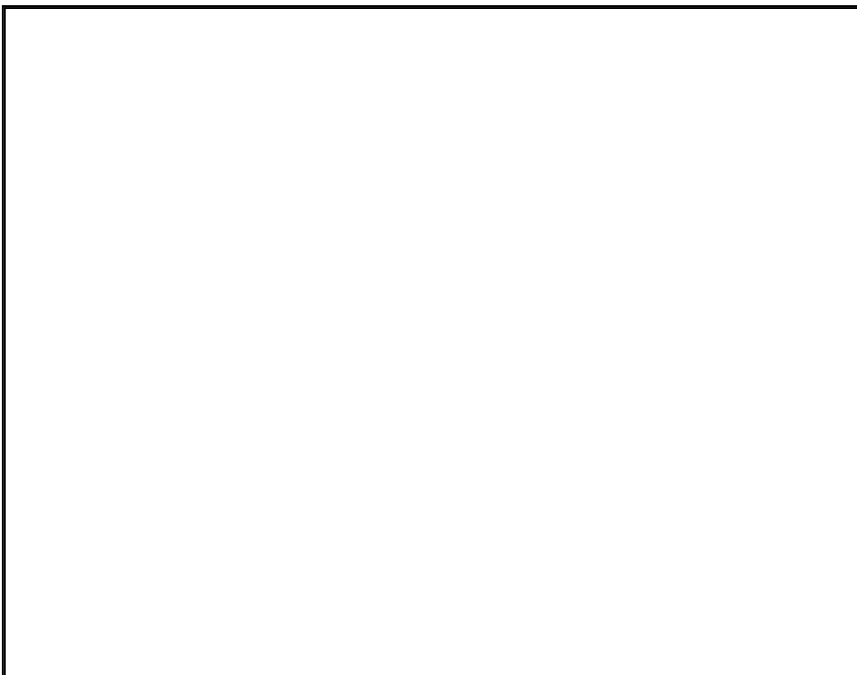

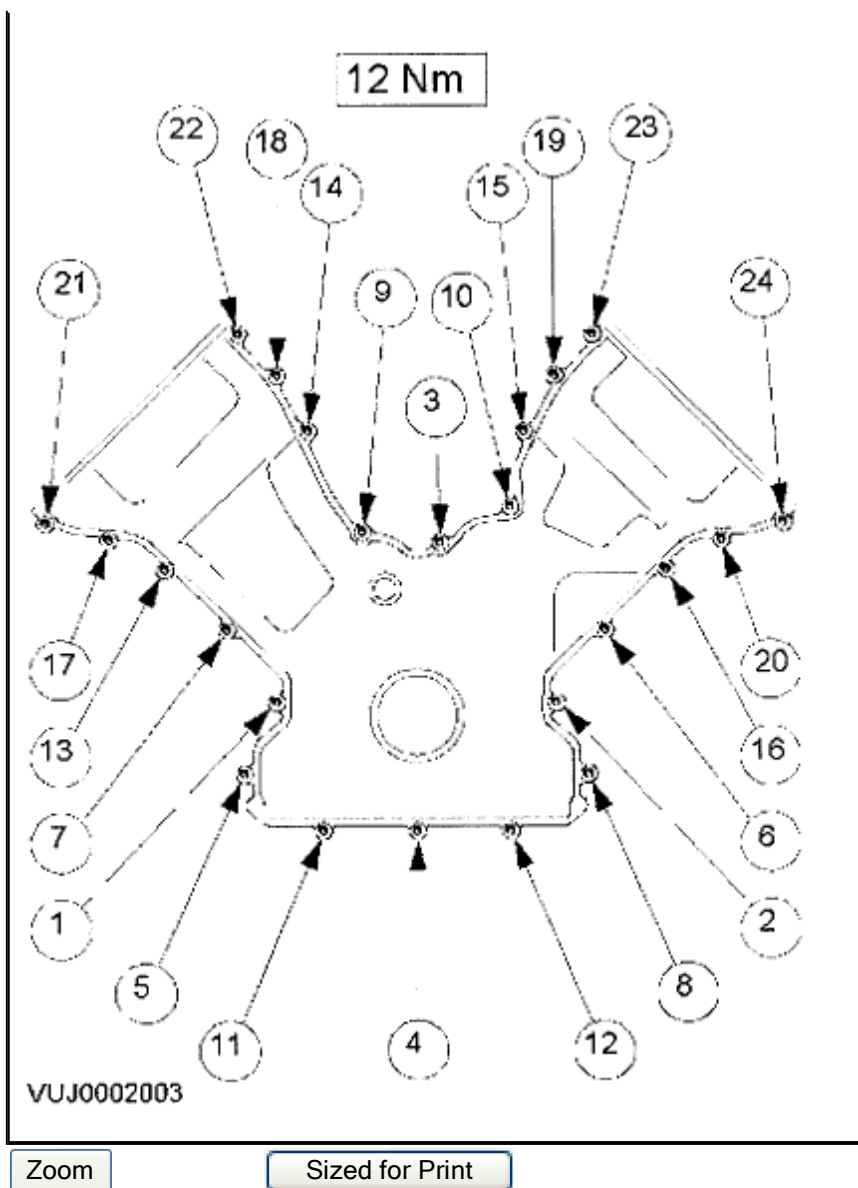

65. Install the [timing cover](#).
66. **NOTE:** Apply an **8 mm** diameter bead of silicone gasket sealant on the two places where the cylinder head and front cover join.



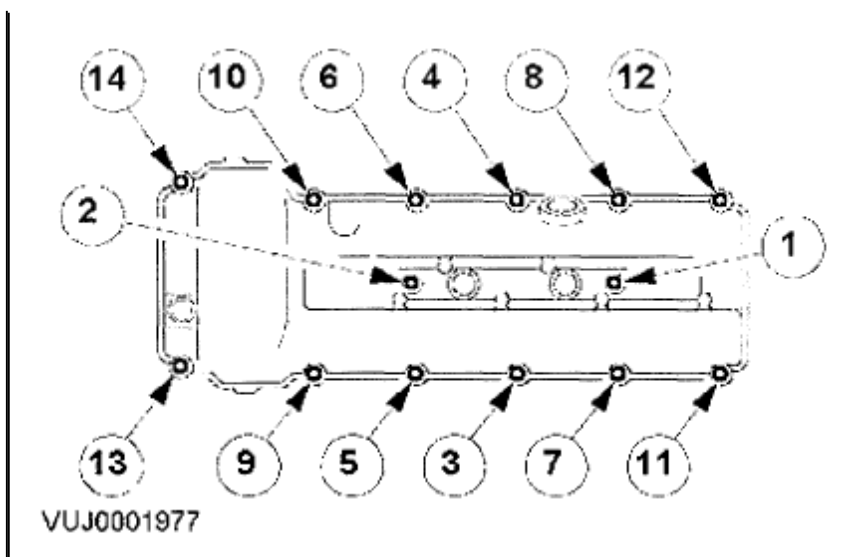

Zoom

Sized for Print

Install the left-hand [valve cover](#).

Install new [valve cover gaskets](#).

Tighten to **10 Nm** .

67. **NOTE:** Apply an **8 mm** diameter bead of silicone gasket sealant on the two places where the cylinder head and front cover join.

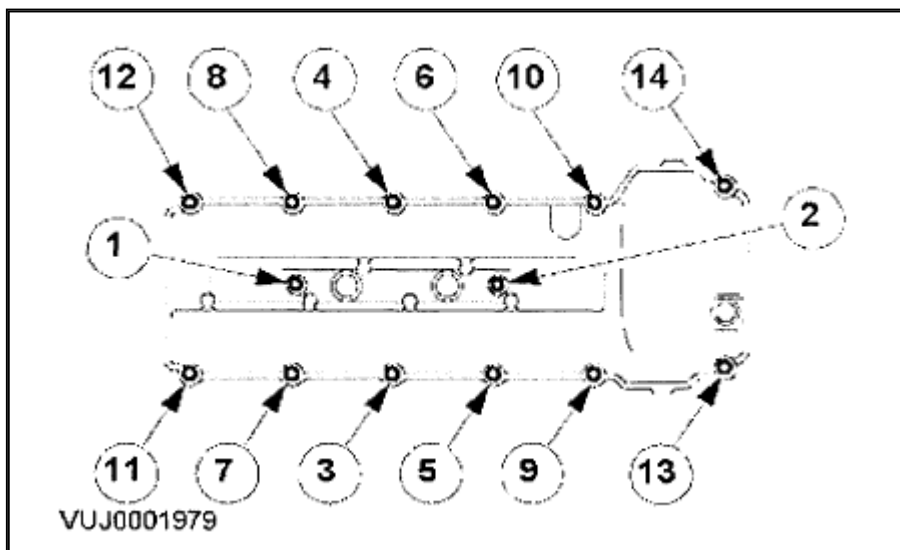

Zoom

Sized for Print

Install the right-hand [valve cover](#).

Install new [valve cover gaskets](#).

Tighten to **10 Nm** .

68. **CAUTION:** Under no circumstances should the [crankshaft](#) setting peg 303-646 be used in the following operations, to lock the crankshaft.

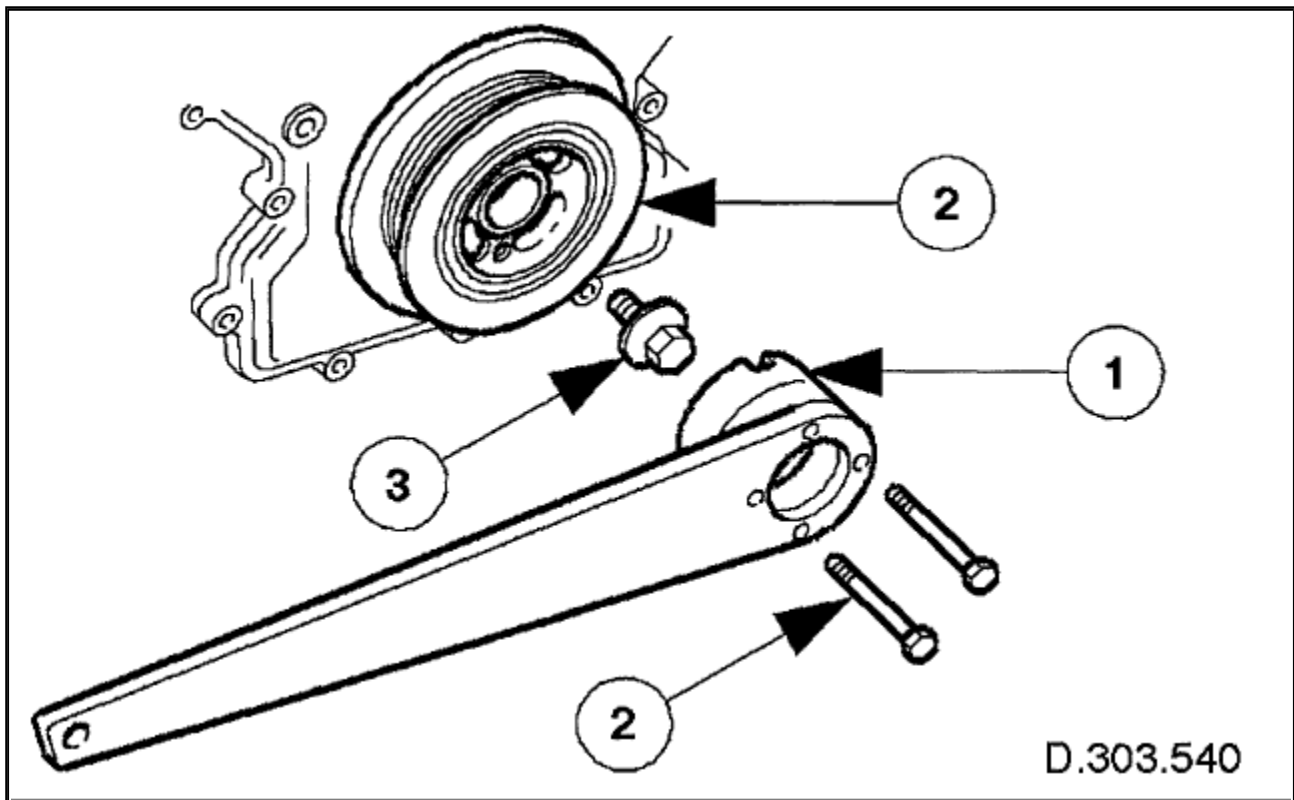

Zoom

Sized for Print

Install the [crankshaft](#) locking tool to the damper.
Install adapter 303-191-02 to the main locking tool 303-191.
Reposition the [crankshaft](#)/damper to align the mounting holes and install the locking tool using the bolts provided.
Install the damper securing bolt to the [crankshaft](#).
Tighten to **375 Nm** .