

00-018

July 25, 2000

Applies To:

1998-00 Accord L4 - See VEHICLES AFFECTED

[MIL](#) Comes On With DTCs P0171 and/or P0172  
(Supersedes 00-018, dated March 14, 2000)

#### SYMPTOM

The [MIL](#) (Malfunction Indicator Lamp) comes on with DTCs P0171 (Fuel System Too Lean) and/or P0172 (Fuel System Too Rich) stored in the [ECM/PCM](#).

#### PROBABLE CAUSE

Moisture in the fuel pressure regulator.

#### VEHICLES AFFECTED

1998-99 2-door: ALL

1998-99 4-door: ALL

2000 2-door:From VIN 1HGCG3. . .YA000001 thru YA000919

2000 4-door:From VIN 1HGCG6. . .YA000001 thru YA002332

From VIN 1HGCG5. . .YA000001 thru YA012613

From VIN JHMCG5. . .YC000001 thru YC000015

VIN JHMCG6. . .YC000001

#### CORRECTIVE ACTION

Replace the fuel pressure regulator, and reroute the fuel pressure regulator vacuum line.

#### WARRANTY CLAIM INFORMATION

Operation Number:	121135
Flat Rate Time:	0.3 hour
Failed Part:	P/N 16740-PAA-A01 H/C 5429048
Defect Code:	091
Contention Code:	B01
Template ID:	Not used for this bulletin.
Skill Level:	Repair Technician

Zoom

Sized for Print

In warranty:  
The normal warranty applies.

Out of warranty:  
Any repair performed after warranty expiration may be eligible for goodwill consideration by the District Service Manager or your Zone Office. You must request consideration, and get a decision, before starting work.

## PARTS INFORMATION

Fuel Pressure Regulator (All):P/N 16740-PAA-A01, H/C 5429048

Fuel Pressure Regulator Tube Kit A (M/T with cruise control):P/N 06168-PAA-A10, H/C 6383186

Fuel Pressure Regulator Tube Kit B (A/T with cruise control):P/N 06168-PAA-A60, H/C 6383160

Fuel Pressure Regulator Tube Kit C (M/T without cruise control):P/N 06168-PAB-A00, H/C 6383194

Fuel Pressure Regulator Tube Kit D (A/T without cruise control):P/N 06168-PAB-A50, H/C 6383178

## REPAIR PROCEDURE

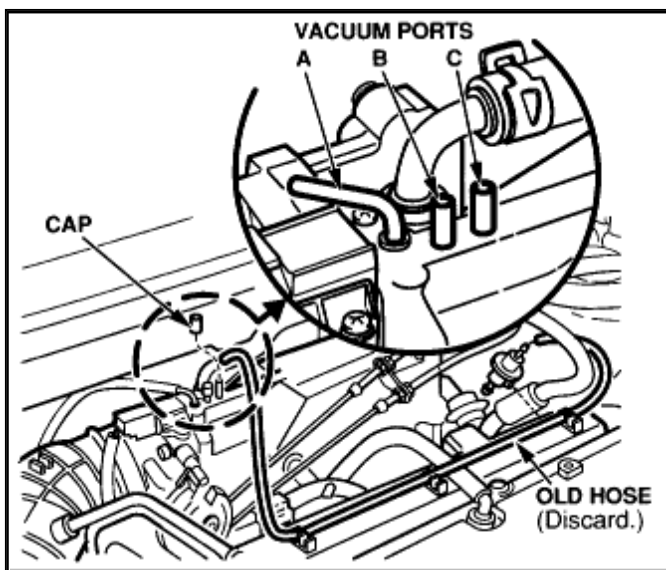

Zoom

Sized for Print

1. Locate and identify the three vacuum ports on the intake manifold.

2. Disconnect and discard the vacuum hose that connects the fuel pressure regulator to vacuum port C.
3. Plug vacuum port C with the cap from the tube kit.
4. Replace the fuel pressure regulator. Refer to page 11-113 of the 1998-00 Accord Service Manual.
5. Install the new vacuum hose kit using one of the following procedures.

**M/T WITH CRUISE CONTROL**

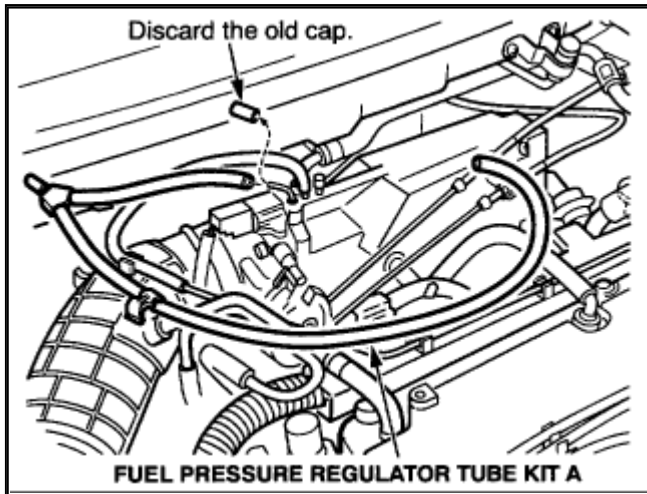

Zoom

Sized for Print

1. Remove and discard the cap from vacuum port A.
2. Connect the short vacuum hose to vacuum port A.

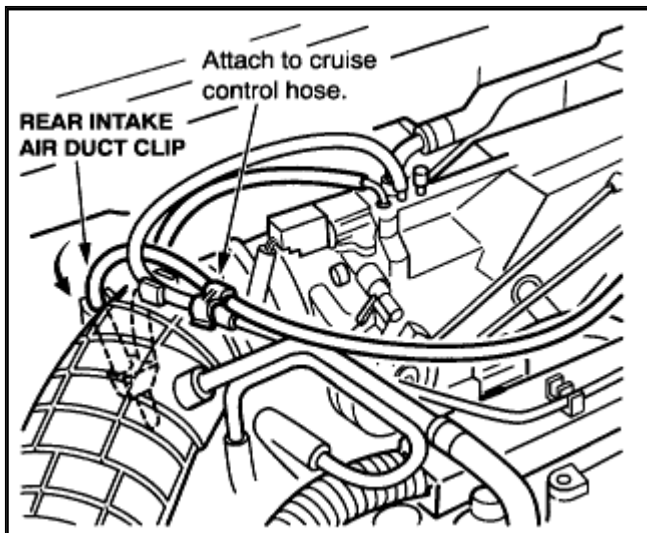

Zoom

Sized for Print

3. Anchor the long vacuum hose by attaching it to the rear intake air duct clip and to the cruise control hose.

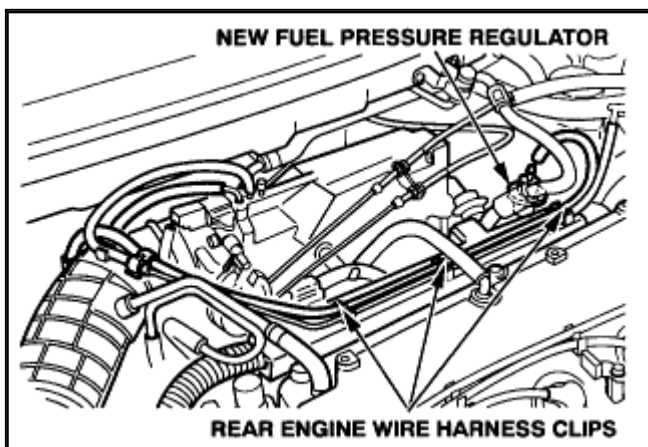

Zoom

Sized for Print

4. Route the new vacuum hose to the fuel pressure regulator. Attach the hose to the three rear clips on the engine wire harness cover.

#### A/T WITH CRUISE CONTROL

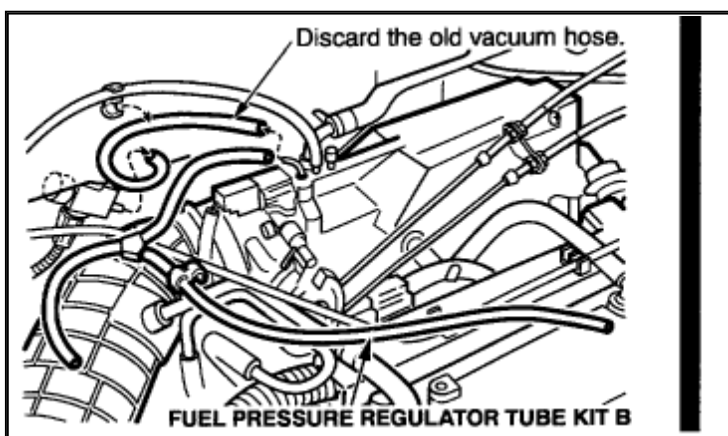

Zoom

Sized for Print

1. Remove and discard the vacuum hose from vacuum port A. This hose supplies vacuum to the rear engine mount control solenoid.
2. Connect the short vacuum hose from the top of the Y fitting to vacuum port A.



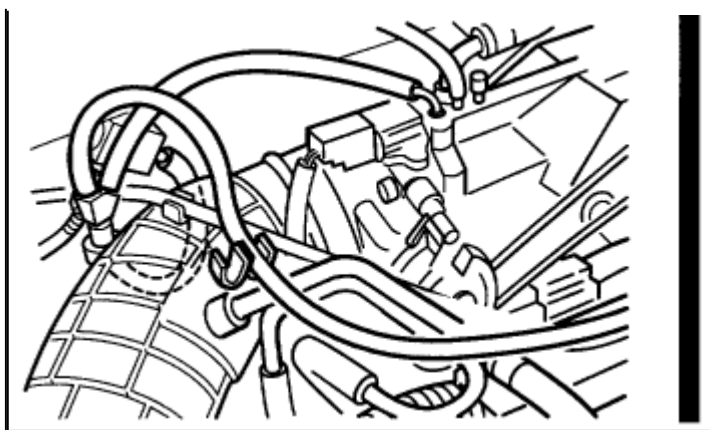

Zoom

Sized for Print

3. Connect the hose from the bottom of the Y fitting onto the engine mount control solenoid.
4. Anchor the long vacuum hose by attaching it to the rear intake air duct clip.

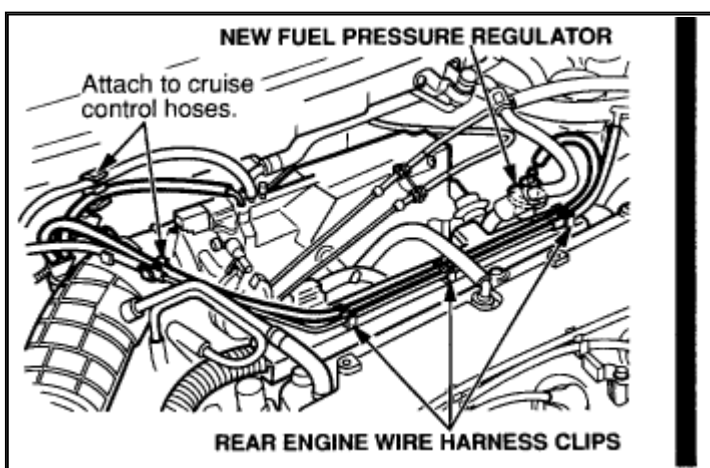

Zoom

Sized for Print

5. Route the long vacuum hose to the fuel pressure regulator. Anchor the hose to the cruise control hose, and to the three rear clips on the engine wire harness cover.

#### M/T WITHOUT CRUISE CONTROL

1. Remove and discard the cap from vacuum port A.



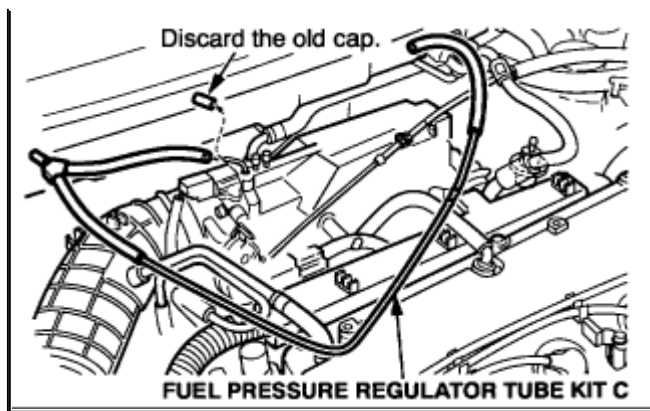

Zoom

Sized for Print

2. Connect the short vacuum hose to vacuum port A.

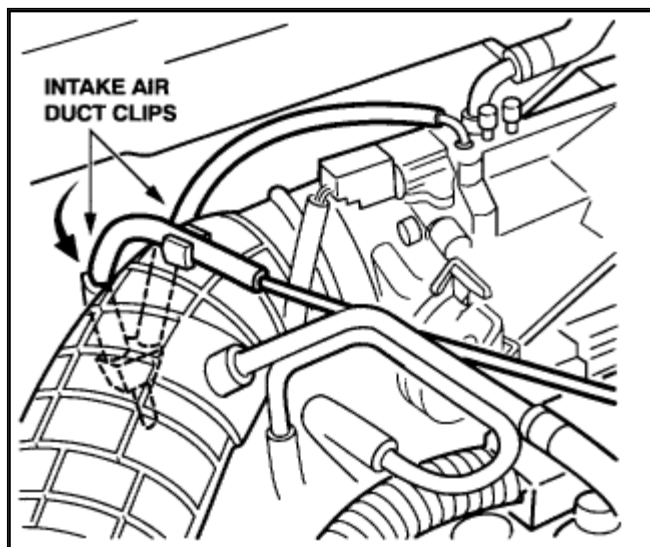

Zoom

Sized for Print

3. Attach the long vacuum hose to the two clips on the intake air duct.

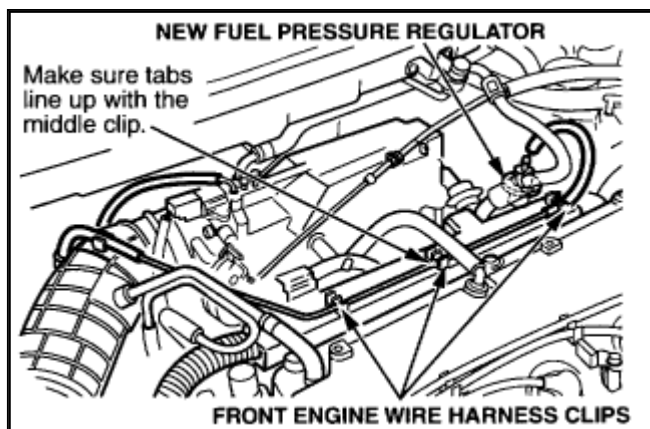

Zoom

Sized for Print

4. Route the new vacuum hose to the fuel pressure regulator. Attach the hose to the three front clips on the engine wire harness cover. Make sure the tabs on the hose line up with the middle clip.

#### A/T WITHOUT CRUISE CONTROL

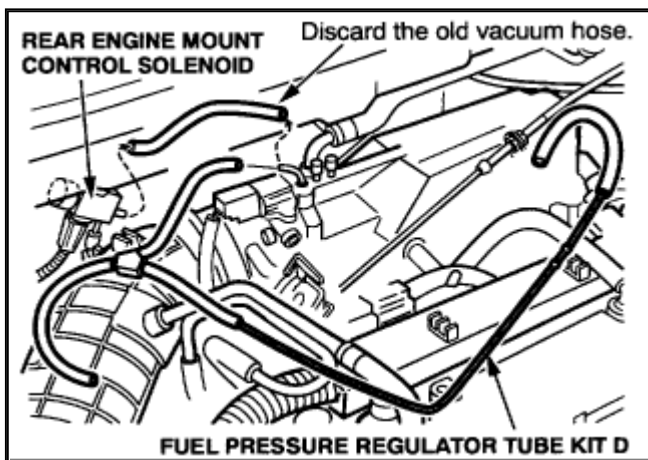

Zoom

Sized for Print

1. Remove and discard the vacuum hose from vacuum port A. This hose supplies vacuum to the rear engine mount control solenoid.
2. Connect the short hose from the top of the Y fitting to vacuum port A.

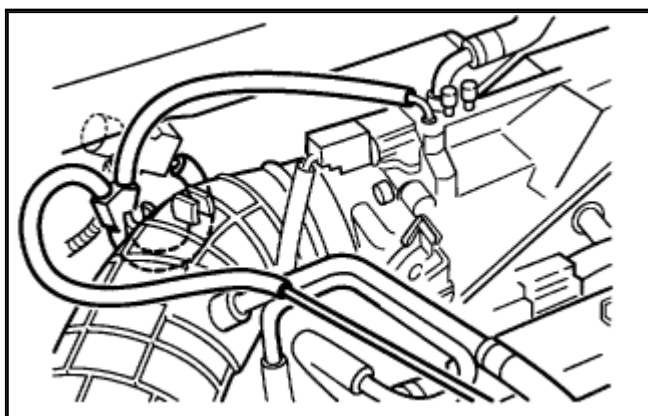

Zoom

Sized for Print

3. Connect the hose from the bottom of the Y fitting onto the engine mount control solenoid.



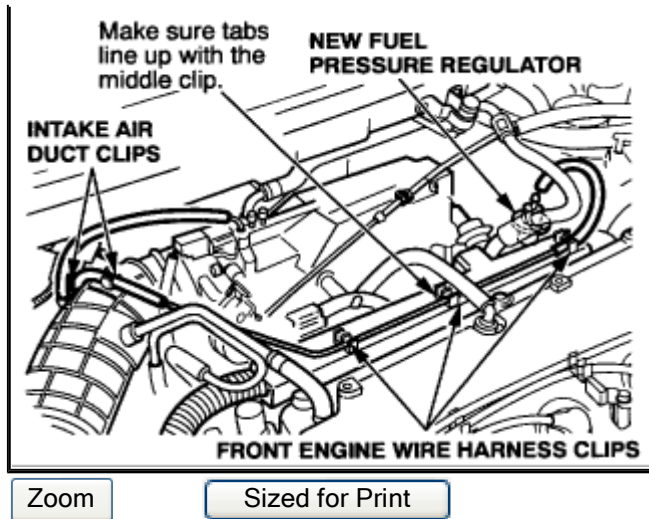

4. Route the new vacuum hose to the fuel pressure regulator. Anchor the long hose to the two intake air duct clips and to the three front clips on the engine wire harness cover. Make sure the tabs on the hose line up with the middle clip.