

IGNITION CHECKS

ELECTRONIC IGNITION SYSTEM

Spark

Check for spark at secondary coil wire and each spark plug wire using a spark tester. If spark is not present, continue with following tests. Check spark plug wire resistance on suspect wires. Resistance should be less than 25,000 ohms.

Ignition Coil Power Source

1. On Civic, remove distributor cap to check power source directly at coil. On all models, disconnect ignition coil primary leads. Turn ignition on. Using voltmeter, check voltage between ground and Black/Yellow wire terminal of ignition coil harness.
2. Battery voltage should be present. If battery voltage is not present, check for open in Black/Yellow wire between coil and ignition switch.

Ignitor Power Source

Turn ignition off. Disconnect harness connector at distributor. Turn ignition on. Using voltmeter, check for battery voltage between ground and Black/Yellow wire of harness. If voltage is not present, check for open in Black/Yellow wire between ignition coil and harness connector. If wire is okay, check ignition coil resistance (for internal short to ground).

Ignitor Check

Check TDC/CRANK/CYL sensor resistance values. See **TACH PULSE SIGNAL** . Check power sources. If no problems are found and spark is not present, replace ignitor.

Ignition Coil Resistance (Accord & Prelude)

1. Remove primary and secondary leads from ignition coil. Using an ohmmeter, check resistance between primary terminals "A" and "C" ("A" and "B" for Prelude) of ignition coil. See **Fig. 2** . Resistance should be .6-.8 ohm at room temperature.
2. On Accord, check resistance between terminals "B" and "D" of ignition coil (tachometer circuit). Resistance should be about 2090-2310 ohms at room temperature.
3. On all models, check secondary resistance between terminal "A" and secondary output terminal (coil tower). See **IGNITION COIL RESISTANCE** table. Check for continuity between terminals "A" and "B" ("A" and "C" for Prelude). Continuity should exist. If readings are not within specification, replace coil.

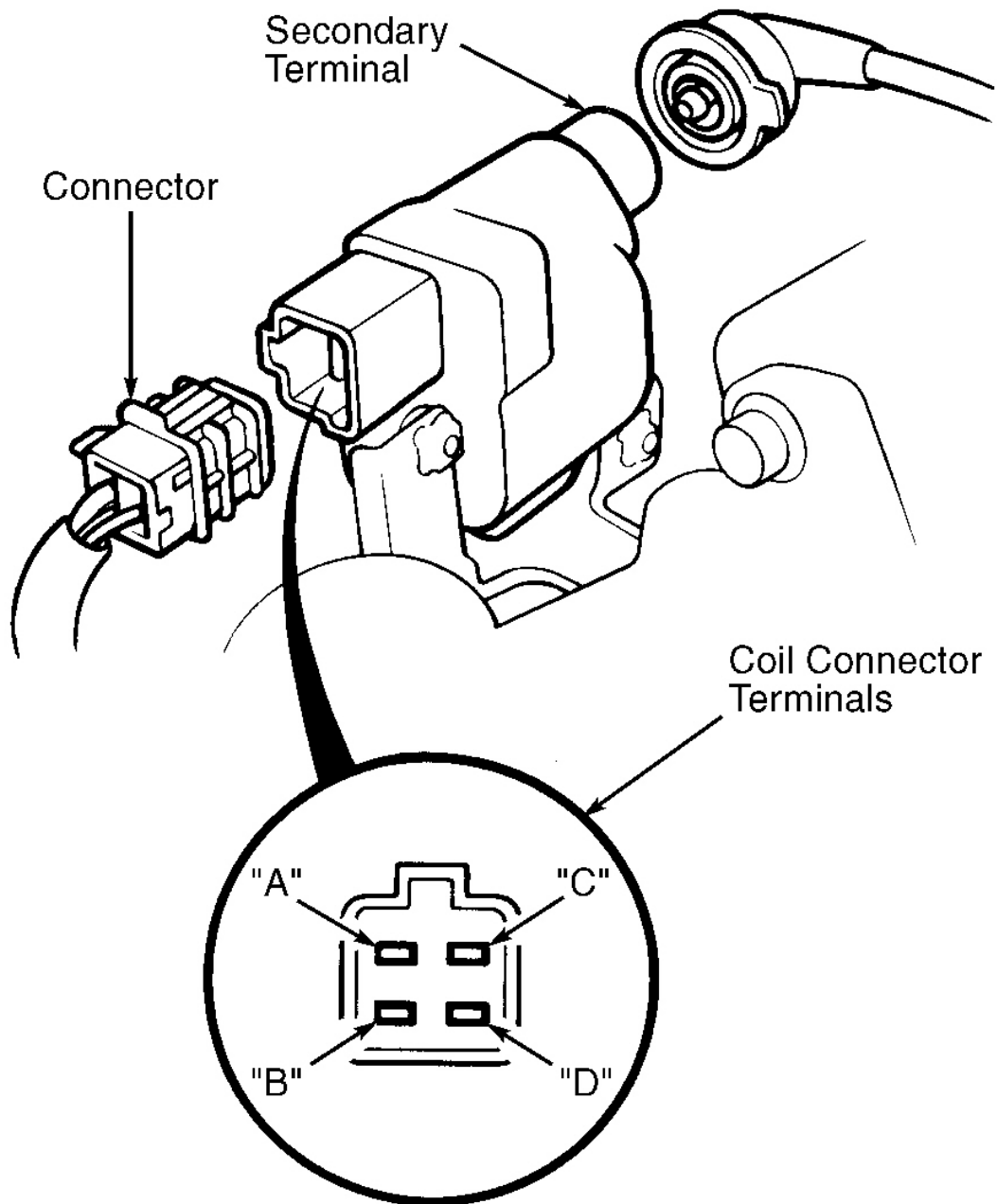

G92A25130

Fig. 2: Identifying Ignition Coil Terminals (Accord & Prelude)
 Courtesy of AMERICAN HONDA MOTOR CO., INC.

IGNITION COIL RESISTANCE - Ohms @ 68°F (20°C)

Application	Primary	Secondary
Accord & Prelude	.6-.8	14,400-21,600



Ignition Coil Resistance (Civic & Civic Del Sol)

1. Turn ignition off. Remove distributor cap. Remove 2 Phillips screws retaining primary ignition leads to ignition coil. Remove primary leads from ignition coil. Using an ohmmeter, check resistance between primary terminals "A" and "B" on ignition coil. See **Fig. 3**. Resistance should be .6-.8 ohm at room temperature.
2. Check secondary resistance between terminal "A" and secondary output terminal (coil tower) at room temperature. See **IGNITION COIL RESISTANCE** table. If readings are not within specification, replace coil.

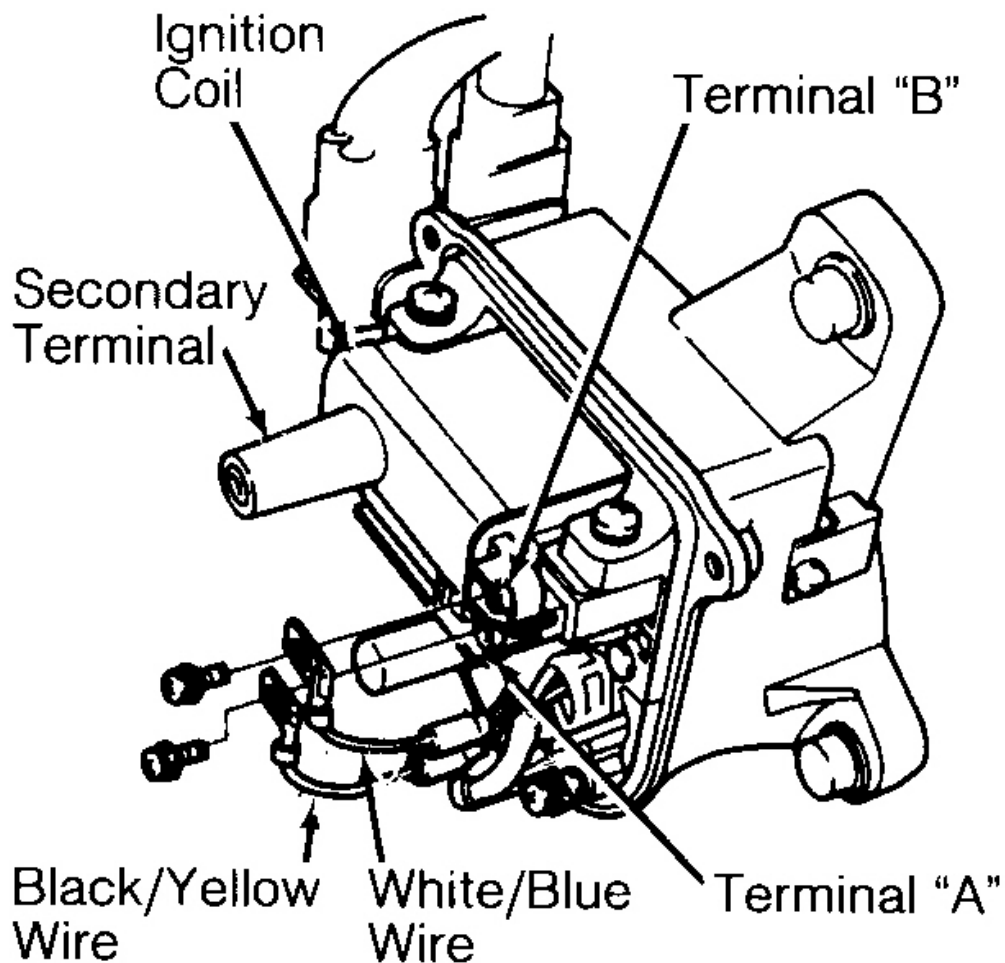

93B78106

Fig. 3: Identifying Ignition Coil Terminals (Civic & Civic Del Sol)
 Courtesy of AMERICAN HONDA MOTOR CO., INC.

Tach Pulse Signal

1. Timing control and triggering of fuel injectors are based upon input signals from TDC/CRANK/CYL sensors. These sensors are simple Permanent Magnet (PM) generator pick-up coils.
2. Using a DVOM on low voltage scale (preferably with a bar-graph function), check for a pulsed low-voltage signal at proper Engine Control Module (ECM) harness terminals with engine cranking. See **Fig. 4**. See **WIRING HARNESS & SENSOR RESISTANCE TEST** table. If a pulsed signal is present, no fault is present. If pulsed signal is not present, check sensor and wiring integrity.

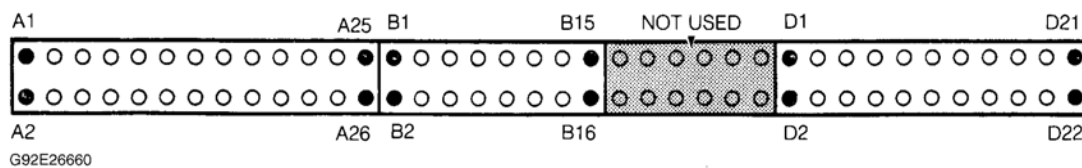

Fig. 4: Identifying ECM Wire Harness Connector Terminals
 Courtesy of AMERICAN HONDA MOTOR CO., INC.

3. To test sensor and wiring integrity, turn ignition off. Disconnect connectors from ECM. Lightly probe appropriate ECM harness terminals to check for proper winding resistance of each sensor. See **WIRING HARNESS & SENSOR RESISTANCE TEST** table. If resistance is within specification, go to step 5). If resistance is not within specification, check resistance of TDC/CRANK/CYL sensor directly at sensor connector. See **Fig. 5**. See **TDC/CRANK/CYL SENSOR RESISTANCE TEST** table.
4. If sensor resistance is now within specification, repair opens, shorts or corrosion in wire harness between sensor(s) and ECM. If resistance is not within specification, replace sensor.
5. If resistance values in step 3) were within specification, check for continuity to ground at each ECM sensor terminal. If continuity is present, disconnect sensor(s) and recheck for continuity to ground at ECM harness sensor terminals. If continuity no longer exists, go to next step. If continuity to ground is still present, repair short to ground in ECM harness between ECM and sensor(s).
6. If continuity did not exist with sensor disconnected, check for continuity to ground on each sensor connector terminal. See **Fig. 5**. See **TDC/CRANK/CYL SENSOR RESISTANCE TEST** table. If continuity to ground exists, replace sensor.

WIRING HARNESS & SENSOR RESISTANCE TEST

Application	Terminals	Ohms
Accord		
CRANK	B15 & B16	260-500
CYL	B11 & B12	260-500
TDC	B13 & B14	260-500
Civic, Civic Del Sol & Prelude		
CRANK	B15 & B16	350-700



1993 Honda Civic del Sol S

1993 ENGINE PERFORMANCE 'Basic Diagnostic Procedures

CYL	B11 & B12	350-700
TDC	B13 & B14	350-700

TDC/CRANK/CYL SENSOR RESISTANCE TEST

Application	Terminals	Wire Color
CRANK Sensor Wire		
1 Of 2	"B"	Blue/Green
2 Of 2	"F"	Blue/Yellow
CYL Sensor Wire		
1 Of 2	"D"	Orange
2 Of 2	"H"	White
TDC Sensor Wire		
1 Of 2	"C"	Orange/Blue
2 Of 2	"G"	White/Blue

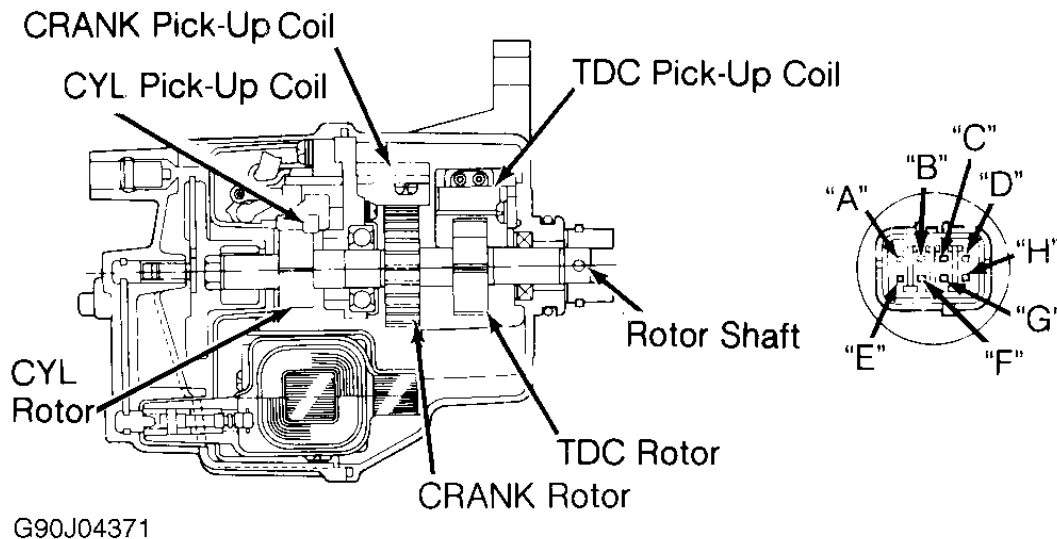

Fig. 5: Identifying TDC/CRANK/CYL Sensor Connector Terminals
 Courtesy of AMERICAN HONDA MOTOR CO., INC.

IDLE SPEED & IGNITION TIMING

Ensure idle speed and ignition timing are set to specification. See **IDLE SPEED SPECIFICATIONS** and **IGNITION TIMING** tables. For adjustment procedures, see **D - ADJUSTMENTS** article in the ENGINE PERFORMANCE Section.

IDLE SPEED SPECIFICATIONS

1993 Honda Civic del Sol S

1993 ENGINE PERFORMANCE 'Basic Diagnostic Procedures

Application	(1) RPM
Accord & Prelude	500-600
Civic & Civic Del Sol	370-470

(1) With Intake Air Control (IAC) valve disconnected, headlights and cooling fan off and transmission in Neutral or Park.

IGNITION TIMING (Degrees BTDC @ RPM)

Application	Specification
Accord & Prelude	13-17 @ 700-800
Civic & Civic Del Sol	
1.5L	
D15B7	
A/T	16 @ 700
M/T	16 @ 650
D15B8	12 @ 650
D15Z1	16 @ 600
1.6L (D16Z6)	
A/T	16 @ 700
M/T	16 @ 650

IGNITION COIL RESISTANCE - Ohms @ 68°F (20°C)

Application	Primary	Secondary
Accord & Prelude	.6-.8	14,400-21,600
Civic & Civic Del Sol	.6-.8	12,800-19,200

WIRING HARNESS & SENSOR RESISTANCE TEST

Application	Terminals	Ohms
Accord		
CRANK	B15 & B16	260-500
CYL	B11 & B12	260-500
TDC	B13 & B14	260-500
Civic, Civic Del Sol & Prelude		
CRANK	B15 & B16	350-700
CYL	B11 & B12	350-700
TDC	B13 & B14	350-700

TDC/CRANK/CYL SENSOR RESISTANCE TEST

Application	Terminals	Wire Color
CRANK Sensor Wire		
1 Of 2	"B"	Blue/Green
2 Of 2	"F"	Blue/Yellow

--	--	--

1993 Honda Civic del Sol S

1993 ENGINE PERFORMANCE' 'Basic Diagnostic Procedures

CYL Sensor Wire		
1 Of 2	"D"	Orange
2 Of 2	"H"	White
TDC Sensor Wire		
1 Of 2	"C"	Orange/Blue
2 Of 2	"G"	White/Blue

IDLE SPEED SPECIFICATIONS

Application	(1) RPM
Accord & Prelude	500-600
Civic & Civic Del Sol	370-470
(1) With Intake Air Control (IAC) valve disconnected, headlights and cooling fan off and transmission in Neutral or Park.	

IGNITION TIMING (Degrees BTDC @ RPM)

Application	Specification
Accord & Prelude	13-17 @ 700-800
Civic & Civic Del Sol	
1.5L	
D15B7	
A/T	16 @ 700
M/T	16 @ 650
D15B8	12 @ 650
D15Z1	16 @ 600
1.6L (D16Z6)	
A/T	16 @ 700
M/T	16 @ 650

--	--	--