

Dash Board / Instrument Panel: Service and Repair

Instrument Panel Assembly Rotating

REMOVAL PROCEDURE

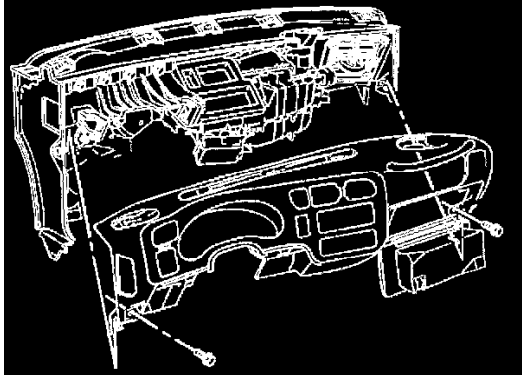

1. On vehicles equipped with a manual transmission, remove the shift lever.
2. On vehicles equipped with an automatic transmission, perform the following steps:
 - 2.1. Apply the park brake.
 - 2.2. Insert the ignition key and turn the ignition switch to the RUN position.
 - 2.3. Depress the brake pedal and shift the transmission to the 1 position.
 - 2.4. Turn the ignition switch to the OFF position.

CAUTION: Refer to **Battery Disconnect Caution** in Cautions and Notices.

3. Disconnect the battery negative cable.
4. Remove the left sound insulator.
5. Remove the right instrument panel sound insulator.
6. If the vehicle is equipped with a multiple CD changer located in the center console, remove the center console.
7. Remove the center sound insulator.
8. Remove the lower left instrument panel mounting bolt.
9. Remove and retain the instrument panel storage compartment.
10. Remove the lower right instrument panel mounting bolt.

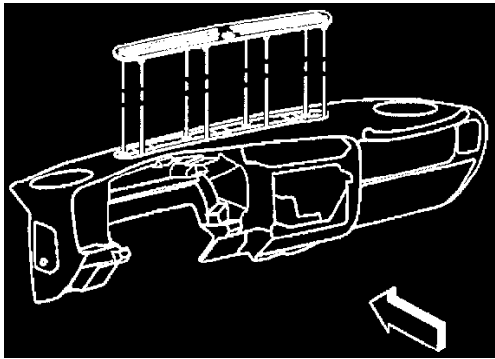

11. Remove and retain the left and right speakers and the speaker grilles.
12. Use a flat-bladed tool in order to remove the windshield defroster grille. Retain the grille and sunload sensor for use on the next IP carrier.

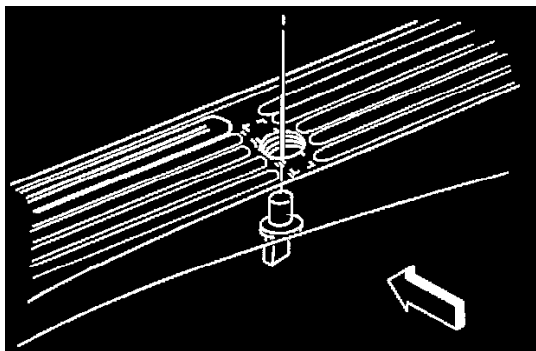

13. If equipped with a sun load temperature sensor twist the sensor 1/4 turn counterclockwise in order to disengage.
14. Disconnect the brown electrical connection from the body control module (BCM).
15. Disconnect the purple electrical connection from the body control module (BCM).
16. Remove the knee bolster.

17. Remove and retain the instrument cluster.
18. Remove and retain the radio.
19. Remove the HVAC control assembly.

CAUTION: Refer to **SIR Handling Caution** in Cautions and Notices.

20. Disable the passenger side SIR system.

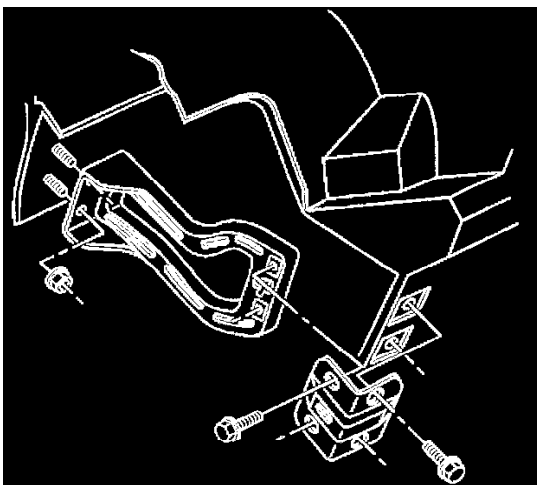

21. Remove the left and right instrument panel driver knee bolster brackets.
22. Lower the steering column for clearance.

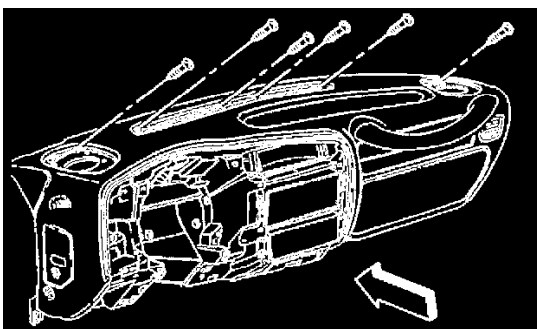

IMPORTANT: Label all of the connections in order to avoid improper installation.

23. Remove the top instrument panel screws.
24. Roll the instrument panel down.
25. Disconnect the electrical connections, as needed.
26. Remove the fastener that retains the radio antenna cable to the instrument panel.
27. Remove the instrument panel from the vehicle. If replacing the instrument panel carrier, retain the parts for assembly of the new instrument panel carrier.

INSTALLATION PROCEDURE

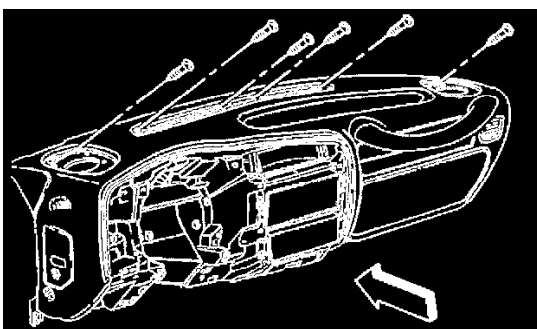

1. Install the retained parts from the original instrument panel.
2. Install the instrument panel to the vehicle.
3. Install the fastener that retains the radio antenna cable to the instrument panel.

Tighten

Tighten the fastener to **1.9 N.m (17 lb in)**.

4. Connect the electrical connectors, as needed.
5. Roll the instrument panel up.
6. Install the top instrument panel screws.

Tighten

Tighten the screws to **1.9 N.m (17 lb in)**.

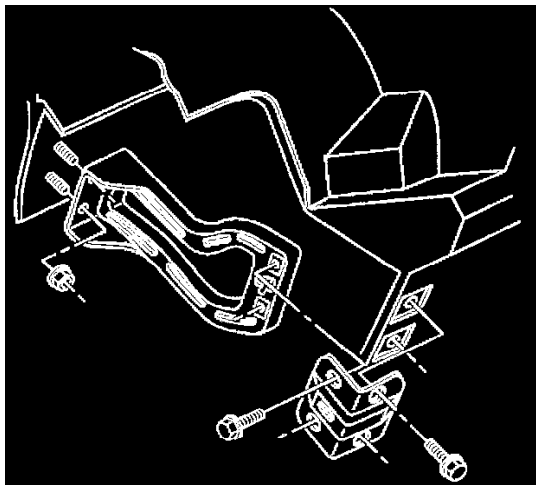

7. Raise the steering column into position.
8. Install the left and right instrument panel driver knee bolster brackets.

Tighten

Tighten the screws/bolts to **6.3 N.m (56 lb in)**.

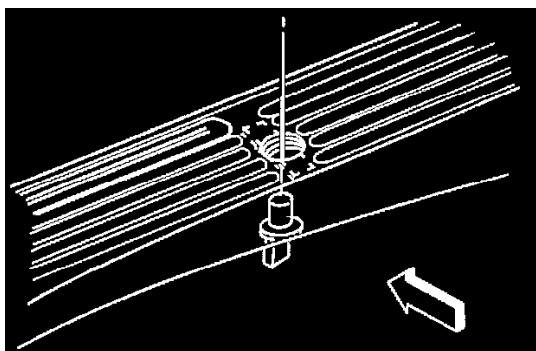

9. Enable the passenger side SIR system.
10. Install the HVAC control assembly to the instrument panel.
11. Install the radio.
12. Install the instrument cluster.
13. Install the knee bolster.
14. Connect the purple electrical connection to the body control module (BCM).
15. Connect the brown electrical connection to the body control module (BCM).
16. If equipped with a sun load temperature sensor, install the sensor to the defroster grille by twisting the sensor 1/4 turn clockwise.

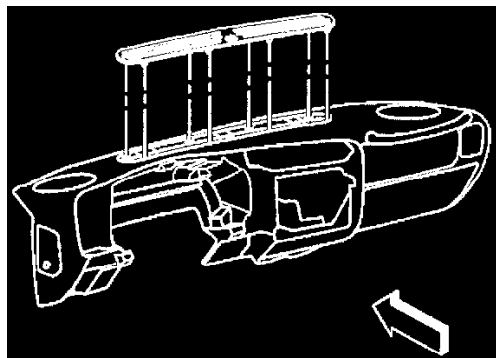

17. Install the windshield defroster grille by pressing carefully pressing the grille into place.
18. Install the left and right speakers and the speaker grilles.

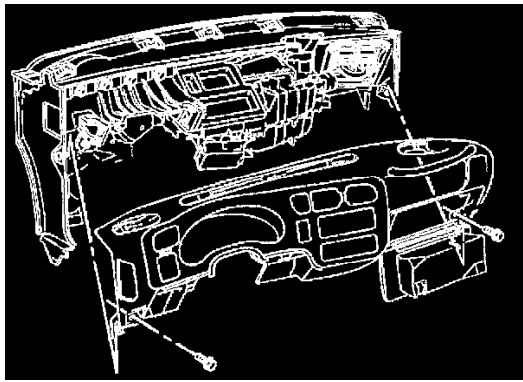

19. Install the lower right instrument panel mounting bolt.

Tighten

Tighten the bolt to **11.5 N.m (102 lb in)**.

20. Install the instrument panel storage compartment.
21. Install the lower left instrument panel bolt.

Tighten

Tighten the bolt to **11.5 N.m (102 lb in)**.

22. Install the center sound insulator.
23. Install the right sound insulator.
24. If the center console was removed, install the console to the vehicle.
25. Install the left sound insulator.
26. Connect the battery negative cable.
27. On vehicles equipped with an automatic transmission, perform the following steps:
 - 27.1. Turn the ignition switch to the RUN position.
 - 27.2. Depress the brake pedal and shift the transmission into the PARK position.
 - 27.3. Release the park brake.
28. On vehicles equipped with a manual transmission, install the shift lever.