

Timing Chain: Service and Repair

Revised Timing Chain, Sprocket, and Tensioner Replacement

Revised Timing Chain, Sprocket, and Tensioner Removal Procedure

Note: GM does not provide timing chain timing marks, or information to perform timing chain service without the special tools shown in this procedure.

Tools Required:

- J 36800 Camshaft Sprocket Timing Alignment Pin
- J 39579 Camshaft Sprocket Wrench

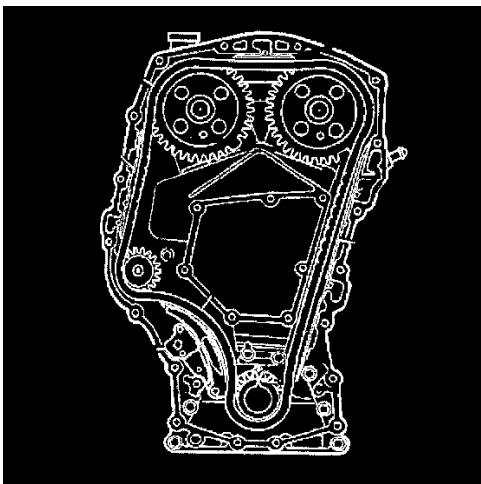

Important:

- ^ Before remove the timing chain, read the entire procedure.
- ^ The timing chain on the engine is not to be replaced with the timing chain from any other model year. The timing sprockets are different on the engine and the shape of the links matches the sprockets. Engine damage may result if the wrong timing chain is used.
- ^ The timing chain and the crankshaft sprocket must be marked in order to insure reassembly with the same side facing out at the time of reassembly.

Caution: Refer to Battery Disconnect Caution in Service Precautions.

1. Disconnect the negative battery cable.
2. Remove the engine front cover. Refer to Engine Front Cover Replacement.
3. Rotate the crankshaft clockwise (as viewed from the front of the engine, normal rotation) until the camshaft sprocket timing dowel pin holes line up with the holes in the timing chain housing.
4. The crankshaft sprocket keyway should point upwards and line up with the centerline of the cylinder bores. This is the Timed position.
5. Remove the timing chain guides.
6. Raise and support the vehicle. Refer to Vehicle Lifting.
7. Ensure that all of the slack in the timing chain is above the tensioner assembly.
8. Remove the timing chain tensioner.
9. The timing chain must be disengaged from any wear grooves in the tensioner shoe in order to remove the shoe. Slide a screwdriver blade under the timing chain while pulling the shoe outward.

Notice: Do **NOT** attempt to pry the sprocket off the camshaft or damage to the sprocket or chain housing could occur.

10. If difficulty is encountered in removing the timing chain tensioner shoe, use the following procedure in order to remove the intake camshaft sprocket:
 - 10.1. Lower the vehicle.
 - 10.2. Hold the intake camshaft sprocket with the J 39579 and remove the sprocket bolt and washer.
 - 10.3. Remove the washer from the bolt and rethread the bolt back into the camshaft by hand (the bolt provides a surface to push against).
 - 10.4. Remove the intake camshaft sprocket. Use a three-jaw puller in the three relief holes in the sprocket.

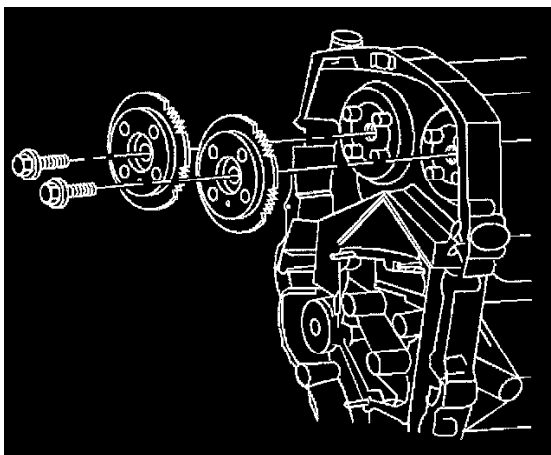

11. Remove the tensioner assembly retaining bolts and tensioner.

Important: The timing chain and the crankshaft sprocket must be marked prior to removal. If the chain or the crankshaft sprocket is installed with the wear pattern in the opposite direction, noise and increased wear may occur.

12. Mark the crankshaft sprocket and the timing chain outer surface.
13. Remove the timing chain.
14. Clean the old sealant off of the bolt with a wire brush.
15. Clean the threaded hole in the camshaft with a round nylon bristle brush.
16. Inspect the parts for wear and replace the parts as necessary.

Some scoring of the timing chain shoe and the guides is normal.

Installation

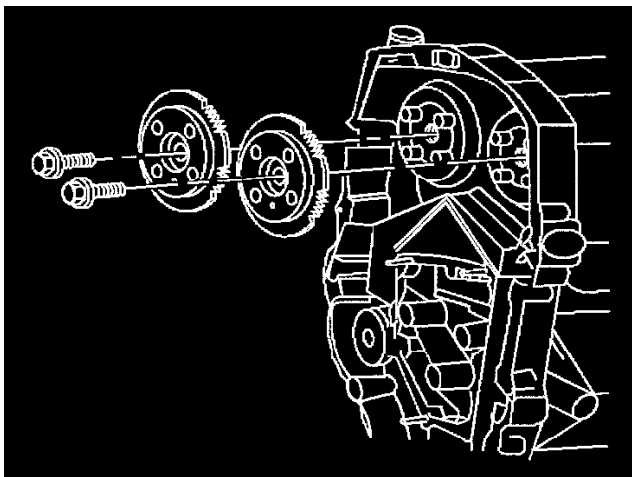

1. Install the camshaft sprockets. The sprockets are identical and interchangeable.
2. Clean the old sealer off of the bolts with a wire brush.
3. Clean the threaded hole in the camshaft with a nylon bristle brush.
4. Coat the camshaft bolts with Adhesive/Sealant Compound GM P/N 1234593 or equivalent.

Notice: Use the correct fastener in the correct location. Replacement fasteners must be the correct part number for that application. Fasteners requiring replacement or fasteners requiring the use of thread locking compound or sealant are identified in the service procedure. Do not use paints, lubricants, or corrosion inhibitors on fasteners or fastener joint surfaces unless specified. These coatings affect fastener torque and joint clamping force and may damage the fastener. Use the correct tightening sequence and specifications when installing fasteners in order to avoid damage to parts and systems.

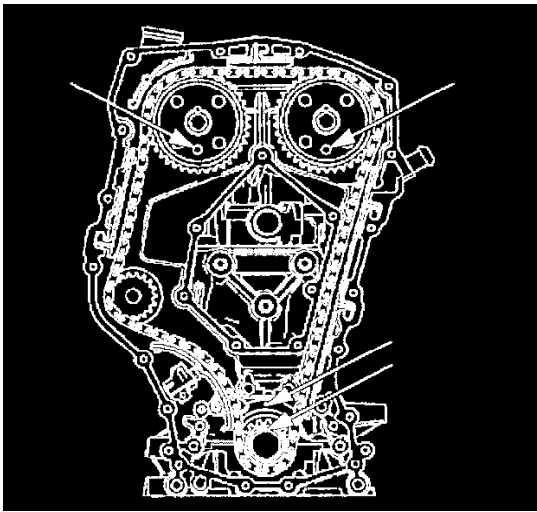

5. Install the camshaft sprocket bolts and washers while holding the sprockets with J 39579.

Tighten

- ^ Tighten the bolts to **70 Nm (52 lb ft)**.

Important: Ensure that the camshaft sprocket alignment pins are in the cylinder block and the timing chain housing, prior to installing the timing chain housing. The camshaft sprocket alignment pins ensure proper chain housing and front cover location for correct front oil seal to crankshaft alignment.

6. Install the J 36008-A through the holes in the camshaft sprockets and into the holes in the timing chain housing. This will position the camshaft for correct timing.
7. Use the following steps if the camshafts are out of position and must be rotated more than 1/8 turn in order to install the alignment dowel pins:
 - A. The crankshaft must be rotated **90°** clockwise off of TDC to give the valves adequate clearance to open.
 - B. Once the camshafts are in position and the dowels are installed, rotate the crankshaft counter clockwise back to TDC.

Notice: Do **NOT** rotate the crankshaft clockwise to TDC. Valve or piston damage could occur.

Important: The timing chain and crankshaft sprocket must be put in a specific direction for chain noise and wear considerations. The surfaces that were marked during removal should be showing when the chain and crankshaft sprocket are installed.

8. Install the timing chain over the exhaust camshaft sprocket around the coolant pump sprocket and around the crankshaft sprocket.
9. Remove the alignment dowel pin from the intake camshaft. Use the J 39579 in order to rotate the intake camshaft sprocket counter clockwise enough to allow the timing chain to slide over the intake camshaft sprocket.
10. Release the J 39579. The length of the chain between the two camshaft sprockets will tighten.

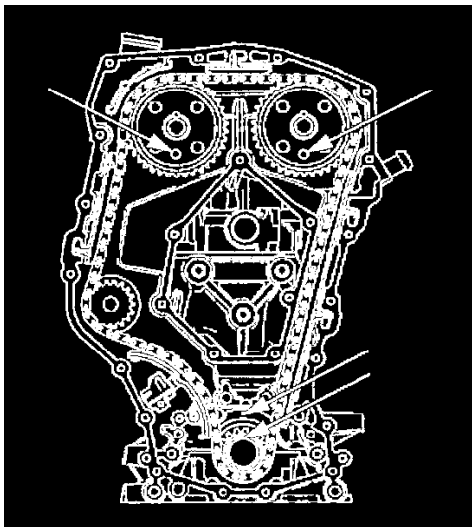

11. If properly timed, the intake camshaft alignment dowel pin will slide in easily. If the dowel pin does not fully index, the camshafts are not timed correctly and the procedure must be repeated.
12. Leave the alignment dowel pins installed.
13. The keyway on the crankshaft and the mark on the cylinder block should be aligned with the slack removed from the chain between the intake camshaft sprocket and the crankshaft sprocket. If the mark and the keyway are not aligned, move the chain one tooth forward or rearward. Remove the slack and recheck the marks.

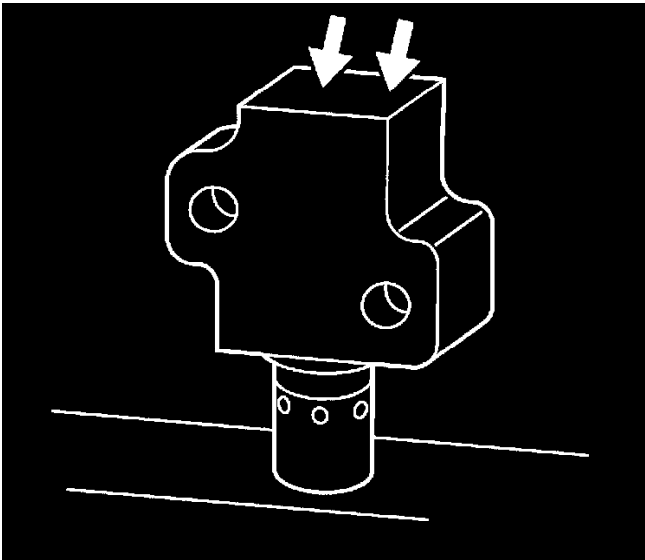

Important: Use the following steps in order to reset the timing chain tensioner assembly to the zero position:

14. Reset the timing chain tensioner assembly.
 - A. Insert the tensioner plunger assembly into the tensioner housing.
 - B. With the tensioner plunger fully extended, turn the complete assembly upside down on a bench or other flat surface.
 - C. With the plunger face against the workbench, press firmly on the bottom of the tensioner housing.
 - D. Compress the plunger until the plunger is seated flush in the tensioner.

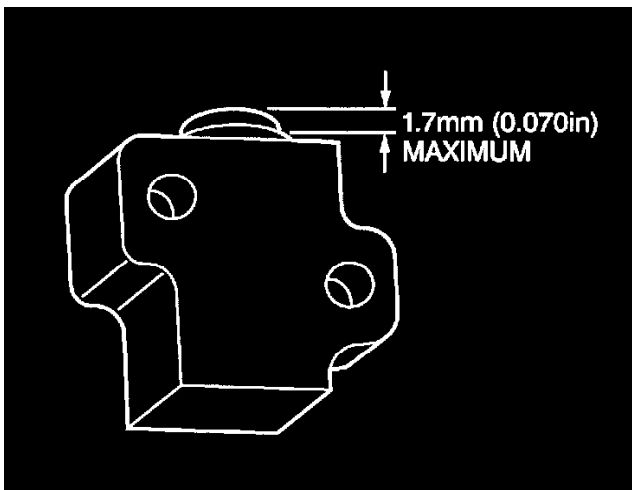

15. Check the plunger to make sure that the plunger is out of the cylinder at the correct dimension. The correct dimension for the plunger to extend out of the cylinder is **1.7 mm (0.07 in)** maximum.

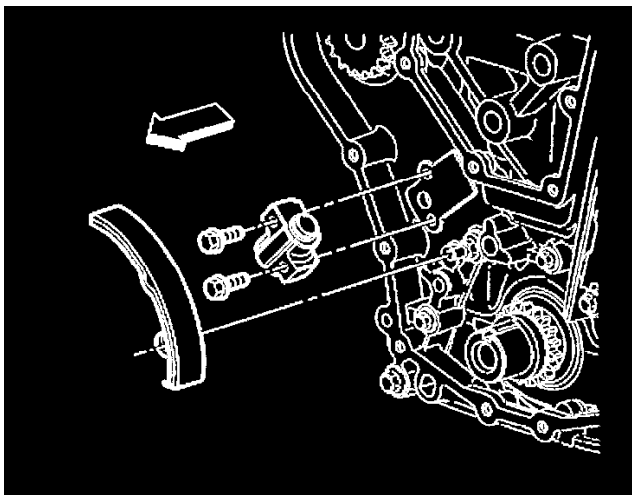

16. Loosely install the tensioner assembly and bolts to the timing chain housing.
17. Install the timing chain tensioner shoe on the stud.
18. Apply hand pressure to the timing chain tensioner shoe until the locking tab seats in the groove in the stud.

19. Tighten the timing chain tensioner bolts. Do not over tighten.

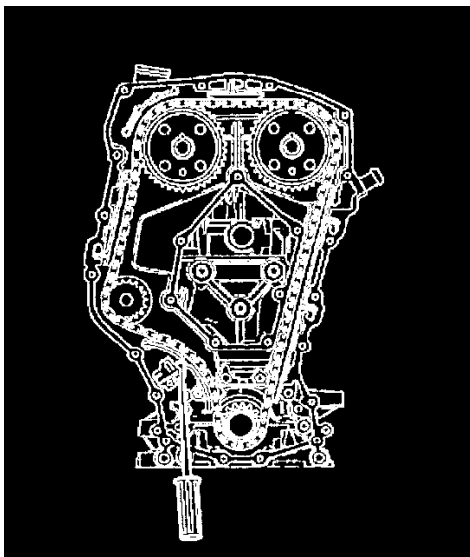

Tighten

- ^ Tighten the bolts to **10 Nm (89 lb in)**.

Notice: If the timing chain tensioner plunger is not released from the installation position, engine damage will occur when the engine is started.

20. Release the timing chain tensioner plunger.

- A. Using a flat blade screwdriver, cotter pin remover, or a similar tool, press firmly against the face of the timing chain tensioner plunger.

Important: If the timing chain tensioner plunger cannot be depressed, the plunger is not properly reset and the procedure for resetting the timing chain tensioner should be repeated.

- B. Depress the timing chain tensioner plunger until the plunger is bottomed out in the bore of the timing chain tensioner.

- C. Release the tensioner plunger. The plunger should press firmly against the back of the timing chain tensioner shoe.

21. Remove the J 36008-A from the camshaft sprockets.

Notice: The timing chain on the engine is different from the chain found on earlier versions of this engine, and is not to be replaced with a timing chain from earlier model year engines. The timing sprockets were also changed and the shape of the chain links matches the sprockets. Engine damage may result if the wrong timing chain is used. The timing chain and the crankshaft sprocket must be marked so that they are reinstalled in the same side facing out at the time of assembly.

22. Rotate the crankshaft clockwise two full rotations. Align the crankshaft keyway with the mark on the cylinder block and reinstall the alignment dowel pins. The alignment dowel pins will slide in easily if the engine is timed correctly.

23. Install the timing chain guides