

#05500: Product Emission - Ignition Distributor System Corrosion-Inspect/Replace - (Apr 28, 2005)

**Subject: 05500 -- IGNITION DISTRIBUTOR SYSTEM CORROSION - INSPECT / REPLACE**

**Models: 2001-2003 CHEVROLET SILVERADO  
2001-2003 GMC SIERRA  
EQUIPPED WITH 4.3L V6 (RPO L35 - VIN W or RPO LU3 - VIN X) ENGINE**

**Condition**

General Motors has decided to conduct a Voluntary Emission Recall involving *certain* 2001-03 Chevrolet Silverado and GMC Sierra model vehicles, equipped with a 4.3L V6 (RPO L35 - VIN W or RPO LU3 - VIN X) engine. The ignition distributor cap and rotor in these vehicles may corrode and cause ignition system failure. This condition may result in rough engine idle, misfire, stalls, engine cranks but does not run and/or illumination of the Malfunction Indicator Lamp (MIL).

**Correction**

Dealers are to inspect the distributor ignition ventilation holes and, if necessary, replace the distributor cap and rotor, remove the External Ignition Protection (EIP) vent screens and install a foam sleeve around the A/C accumulator line.

**Vehicles Involved**

Involved are *certain* 2001-03 Chevrolet Silverado and GMC Sierra model vehicles, equipped with a 4.3L V6 (RPO L35 - VIN W or RPO LU3 - VIN X) engine and built within these VIN breakpoints:

Year	Division	Model	From	Through
2001	Chevrolet	Silverado	11254299	11408126
			1Z204925	1Z335201
2001	GMC	Sierra	11259091	11397187
			1Z217522	1Z335203
2002	Chevrolet	Silverado	21100186	21425577

			2Z100001	2Z348508
2002	GMC	Sierra	21100134	21418507
			2Z100005	2Z348509
2003	Chevrolet	Silverado	31106515	31307932
			3Z100002	3Z272848
2003	GMC	Sierra	31100015	31307889
			3Z100004	3Z272812

**Important:** Dealers should confirm vehicle eligibility through *GMVIS* (GM Vehicle Inquiry System) prior to beginning recall repairs. [Not all vehicles within the above breakpoints may be involved.]

### **For US and Canada**

For dealers with involved vehicles, a Campaign Initiation Detail Report containing the complete Vehicle Identification Number, customer name and address data has been prepared and will be loaded to the GM DealerWorld (US) Recall Information, GMinfoNet (Canada) Recall Reports. Dealers will not have a report available if they have no involved vehicles currently assigned.

### **For Export**

For dealers with involved vehicles, a Campaign Initiation Detail Report containing the complete Vehicle Identification Number, customer name and address data has been prepared, and is being furnished to involved dealers. Dealers will not receive a report with the recall bulletin if they have no involved vehicles currently assigned.

The Campaign Initiation Detail Report may contain customer names and addresses obtained from Motor Vehicle Registration Records. The use of such motor vehicle registration data for any purpose other than follow-up necessary to complete this recall is a violation of law in several states/provinces/countries. Accordingly, you are urged to limit the use of this report to the follow-up necessary to complete this recall.

## **Parts Information**

### **For Standard Recall Parts Distribution Use**

Parts required to complete this recall are to be obtained from General Motors Service Parts Operations (GMSPO). Please refer to your "involved vehicles listing" prior to ordering requirements. Normal orders should be placed on a DRO = Daily Replenishment Order. An emergency requirement should be ordered on a CSO = Customer Special Order.

**Important:** An initial supply of distributor rotors and caps required to complete this recall will be pre-

shipped to involved dealers of record. This pre-shipment is scheduled to begin the week of April 21 2005 and will be approximately 10% of each dealer's involved vehicles. Pre-shipped parts will be charged to dealer's open parts account.

Additional parts, if required, are to be obtained from General Motors Service Parts Operations (GMSPO). Please refer to your "involved vehicles listing" prior to ordering requirements. Normal orders should be placed on a DRO = Daily Replenishment Order. An emergency requirement should be ordered on a CSO = Customer Special Order.

Part Number	Description	Qty/ Vehicle
10452458	Cap, Distributor (V6)	1, if required
10452457	Rotor, Distributor (V6)	1, if required
15190971	Foam Sleeve	1, if required

### Service Procedure

1. Raise the engine hood and inspect the ignition distributor ventilation holes, located in the base of the distributor, to see if the External Ignition Protection (EIP) screens are present.
2. If the EIP vent screens are present:
  - Remove the vent EIP screens using the procedure listed in Step 3.
  - Refer to the appropriate procedure in the Engine Controls sub-section of the applicable Service Manual and replace the distributor cap and rotor.

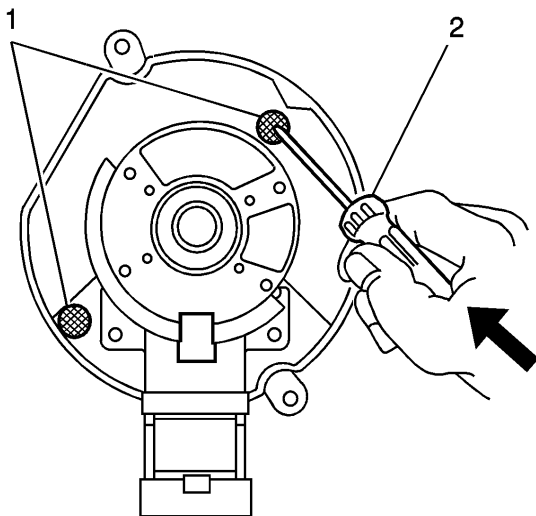

3. Remove the vent screens (1), located in the base of the distributor, by inserting a plastic-handled, long blade awl or pick (2) into each of the two airflow vent holes and popping out the screen. If there are no EIP vent screens in the airflow vent holes, check the vent holes for debris

and clear as necessary before reassembling the distributor.

4. If the EIP vent screens are not present, the distributor cap and rotor do not require replacement.
5. Install the foam sleeve, P/N 15190971, around the section of the A/C accumulator line that is routed directly above the distributor. Cut a slit in the sleeve and secure it to the line using tie-straps. Do not install a new foam sleeve if a sleeve is already in place on the A/C accumulator line.
6. *2001-03 CALIFORNIA, 2003 MASSACHUSETTS & MAINE VEHICLES ONLY* : Install a Recall Identification Label. Also, for California vehicles, complete a "Proof Of Correction" certificate upon recall completion.

### **Recall Identification Label -- 2001-03 California, 2003 Massachusetts & Maine Vehicles Only**

Place a Recall Identification Label on each vehicle corrected in accordance with the instructions outlined in this Product Recall Bulletin. Each label provides a space to include the recall number and the five-digit dealer code of the dealer performing the recall service. This information may be inserted with a typewriter or a ballpoint pen.

Put the Recall Identification Label on a clean and dry surface of the radiator core support in an area that will be visible to people servicing the vehicle.

When installing the Recall Identification Label, be sure to pull the tab to allow adhesion of the clear protective covering. Additional Recall Identification Labels for US dealers can be obtained from Dealer Support Materials by either ordering on the web from DWD Store, [gm.dealerworld.com](http://gm.dealerworld.com), or calling 1-866-700-0001 (Monday-Friday, 8:00 a.m. to 5:00 p.m. EST). Request Item Number S-1015 when ordering.

### **Customer Reimbursement - For US**

All customer requests for reimbursement for previous repairs for the condition will be handled by the Customer Assistance Center, not by dealers.

A General Motors Product Recall Customer Reimbursement Procedure Form is included with the customer letter.

**Important:** Refer to the GM Service Policies and Procedures Manual, section 6.1.12, for specific procedures regarding customer reimbursement and the form.

### **Customer Reimbursement - For Canada and Export**

Customer requests for reimbursement of previously paid repairs to correct the ignition distributor cap and rotor are to be submitted by May 31, 2006.

All reasonable customer paid receipts should be considered for reimbursement. The amount to be reimbursed will be limited to the amount the repair would have cost if completed by an authorized General Motors dealer.

When a customer requests reimbursement, they must provide the following:

- Proof of ownership at time of repair.
- Original paid receipt confirming the amount of repair expense(s) that were not reimbursed, a description of the repair, and the person or entity performing the repair.

Claims for customer reimbursement on previously paid repairs are to be submitted as required by WINS.

**Important:** Refer to the GM Service Policies and Procedures Manual, section 1.6.2, for specific procedures regarding customer reimbursement verification.

### Courtesy Transportation - For US and Canada Only

The General Motors Courtesy Transportation program is intended to minimize customer inconvenience when a vehicle requires a repair that is covered by the New Vehicle Limited Warranty. The availability of courtesy transportation to customers whose vehicles are within the warranty coverage period and involved in a product recall is very important in maintaining customer satisfaction. Dealers are to ensure that these customers understand that shuttle service or some other form of courtesy transportation is available and will be provided at no charge. Dealers should refer to the General Motors Service Policies and Procedures Manual for Courtesy Transportation guidelines.

### Claim Information

Submit a Product Recall Claim with the information indicated below.

Repair Performed	Part Count	Part No.	Parts Allow	CC-FC	Labor Op	Labor Hours	Net Item
Inspect vent holes for EIP screens. Remove EIP vent screens and replace distributor cap and rotor.  Install A/C line foam sleeve	--	--	*	MA-9 6	V1351	0.5 Add: 0.1	N/A
Inspect vent holes for EIP screens. No EIP screens present and no cap or rotor replacement required.  Install A/C line foam sleeve	N/A	N/A	*	MA-9 6	V1352	0.5 Add: 0.1	N/A
Courtesy Transportation (US & Canada Only)	N/A	N/A	N/A	MA-9 6	**	N/A	***
Customer Reimbursement (Canadian & Export Dealers/US CAC)	N/A	N/A	N/A	MA-9 6	V1353	0.2	****

\* The "Parts Allowance" should be the sum total of the current GMSPO Dealer net price plus applicable Mark-Up or Landed Cost Mark-Up (for Export) for distributor cap, rotor and/or foam sleeve needed to complete the repair.

\*\* Submit courtesy transportation using normal labor operations for courtesy transportation as

indicated in the GM Service Policies and Procedures Manual.

\*\*\* The amount identified in the "Net Item" column should represent the actual dollar amount for courtesy transportation.

\*\*\*\* The amount identified in the "Net Item" column should represent the dollar amount reimbursed to the customer.

Refer to the General Motors WINS Claim Processing Manual for details on Product Recall Claim Submission.

### **Customer Notification - For US and Canada**

General Motors will notify customers of this recall on their vehicle (see copy of customer letter included with this bulletin).

In order to ensure full protection under the emission warranty, and the right to participate in future recalls, the customer notification letter recommends that customers have their vehicles serviced as soon as possible. It also advises that failure to do so could legally be determined to be lack of proper maintenance. The vehicle may fail a state or local emission inspection test if the recall work is not completed.

### **Customer Notification - For Export**

Letters will be sent to known owners of record located within areas covered by the US National Traffic and Motor Vehicle Safety Act. For owners outside these areas, dealers should notify customers using the attached sample letter.

In order to ensure full protection under the emission warranty, and the right to participate in future recalls, the customer notification letter recommends that customers have their vehicles serviced as soon as possible. It also advises that failure to do so could legally be determined to be lack of proper maintenance. The vehicle may fail a state or local emission inspection test if the recall work is not completed.

### **Dealer Recall Responsibility - ALL**

All unsold new vehicles in dealers' possession and subject to this recall must be held and inspected/repaired per the service procedure of this recall bulletin before customers take possession of these vehicles.

Dealers are to service all vehicles subject to this recall at no charge to customers, regardless of mileage, age of vehicle, or ownership, from this time forward.

Customers who have recently purchased vehicles sold from your vehicle inventory, and for which there is no customer information indicated on the dealer listing, are to be contacted by the dealer. Arrangements are to be made to make the required correction according to the instructions contained in this bulletin. A copy of the customer letter is provided in this bulletin for your use in contacting customers. Recall follow-up cards should not be used for this purpose, since the customer may not as yet have received the notification letter.

In summary, whenever a vehicle subject to this recall enters your vehicle inventory, or is in your

dealership for service in the future, you must take the steps necessary to be sure the recall correction has been made before selling or releasing the vehicle.

\*\*\*THE FOLLOWING 2 PARAGRAPHS ARE NOT FOR CANADA OR EXPORT\*\*\*

When a California emissions recall is completed by a GM dealer, the dealer must provide the vehicle owner a "Proof Of Correction Certificate" which the owner may need to present to the California Department Of Motor Vehicles (DMV) when renewing their vehicle registration. Without this correction certificate, the owner may be unable to renew their vehicle registration.

Additional Certificates can be obtained, at no charge, from Dealer Support Materials by calling 1-866-700-0001 (Monday-Friday, 8:00 a.m. to 5:00 p.m. EST). Ask for GM Item Number 1825 when ordering.

May 2005

Dear General Motors Customer:

This notice is sent to inform you that General Motors is conducting a voluntary emission recall that includes your vehicle.

### **Reason For This Recall**

Your 2001-03 Chevrolet Silverado or GMC Sierra model vehicle, equipped with a 4.3L V6 engine, has an ignition distributor cap and rotor that may corrode and cause ignition system failure. This may result in rough engine idle, misfire, stalls, engine cranks but does not start and/or illumination of the Malfunction Indicator Lamp (MIL).

### **What Will Be Done**

Your dealer will inspect the ignition distributor ventilation holes and, if necessary, replace the distributor cap and rotor, remove the distributor vent screens and install a foam sleeve around the A/C accumulator line. This service will be performed for you at *no charge*.

### **How Long Will the Repair Take?**

This service correction will take approximately 40 minutes. However, due to service scheduling requirements, your dealer may need your vehicle for a longer period of time.

### **Contacting Your Dealer**

Please contact your GM dealer as soon as possible to arrange a service date and to assure parts availability. Instructions for making this correction have been sent to your dealer. Please ask your dealer if you wish to know how much time will be needed to schedule, process and repair your vehicle.

If you have any questions or need any assistance, just contact your dealer or the appropriate Customer Assistance Center at the number listed below. The Customer Assistance Center's hours of operation are from 8:00 AM to 11:00 PM, EST, Monday through Friday.

<b>Division</b>	<b>Number</b>	<b>Text Telephones (TTY)</b>
Chevrolet	1-800-630-2438	1-800-833-2438

GMC	1-866-996-9463	1-800-462-8583
Puerto Rico - English	1-800-496-9992	
Puerto Rico - Español	1-800-496-9993	
Virgin Islands	1-800-496-9994	
Guam	1-671-648-8650	

### **Customer Reply Form**

The enclosed customer reply form identifies your vehicle. Presentation of this form to your dealer will assist in making the necessary correction in the shortest possible time. If you no longer own this vehicle, please let us know by completing the card and mailing it back to us.

### **Reimbursement**

The enclosed form explains what reimbursement is available and how to request reimbursement if you have paid for repairs for the recall condition.

### **Courtesy Transportation**

If your vehicle is within the New Vehicle Limited Warranty your dealer may provide you with shuttle service or some other form of courtesy transportation while your vehicle is at the dealership for this repair. Please refer to your Owner's Manual and your dealer for details on Courtesy Transportation.

### **Emission Law Information**

In order to ensure your full protection under the emission warranty made applicable to your vehicle by State or Federal Law, and your right to participate in future recalls, it is recommended that you have your vehicle serviced as soon as possible. Failure to do so could legally be determined to be lack of proper maintenance of your vehicle. Also, your vehicle may fail a state or local emission inspection if this recall is not accomplished.

### **IMPORTANT MESSAGE FOR CALIFORNIA RESIDENTS**

*The California Air Resources Board (CARB) requires vehicle emission recalls be completed prior to California registration renewal. Uncorrected emission recalls will result in the inability to renew your California vehicle registration.*

*At the time of emission recall completion, your California dealer will issue a "Proof Of Correction Certificate". Keep this certificate and, if required, present it to the Department of Motor Vehicles when renewing your California registration as proof of recall completion.*

## My GMLink Online

This free online service offers vehicle and ownership related information and tools tailored to your specific vehicle. To join, visit [www.mygmlink.com](http://www.mygmlink.com) , and enter your vehicle's 17-character vehicle identification number (VIN) shown on the enclosed customer reply form to get the most personalized information for your vehicle.

We are sorry to cause you this inconvenience; however, we have taken this action in the interest of your continued satisfaction with our products.

General Motors Corporation

Enclosure

05500

GM bulletins are intended for use by professional technicians, NOT a "do-it-yourselfer". They are written to inform these technicians of conditions that may occur on some vehicles, or to provide information that could assist in the proper service of a vehicle. Properly trained technicians have the equipment, tools, safety instructions, and know-how to do a job properly and safely. If a condition is described, DO NOT assume that the bulletin applies to your vehicle, or that your vehicle will have that condition. See your GM dealer for information on whether your vehicle may benefit from the information.

WE SUPPORT  
VOLUNTARY  
TECHNICIAN  
CERTIFICATION

© 2009 General Motors Corporation. All rights reserved.